

AIRFILM  
CAMERA SYSTEMS

REPORT AFM-505-206

INSTALLATION INSTRUCTIONS  
UTILITY MOUNT ASSY  
BELL 505 SERIES HELICOPTER

**DATE ISSUED: 01/18/2021**



Airfilm Camera Systems  
6245 Aerodrome Way, Hangar No. 2  
Georgetown, CA 95634

**LOG OF REVISIONS**

REVISION	DATE	COMMENTS
N/C	01/18/2021	Original Issue
A	09/14/2021	Minor Changes – Added Figures, Torque Values, Revised W&B Tables, Revised Installation Steps
B	05/12/2022	Revised Document name from AFM-505-INST to AFM-505-206 to match PSCP (Cover Page and Page Headers)

AIRFILM CAMERA SYSTEMS INC PROPRIETARY RIGHTS ARE INCLUDED IN THE INFORMATION DISCLOSED HEREIN. NEITHER THESE DOCUMENTS NOR THE INFORMATION DISCLOSED HEREIN SHALL BE REPRODUCED, USED, OR DISCLOSED IN WHOLE OR IN PART WITHOUT THE WRITTEN PERMISSION OF AIRFILM CAMERA SYSTEMS INC.

# TABLE OF CONTENTS

1.0	INTRODUCTION AND DESCRIPTION .....	1
2.0	AFM-505-1 LH NOSE UTILITY MOUNT INSTALLATION.....	2
3.0	REMOVING THE AFM-505-1 NOSE UTILITY MOUNT ASSEMBLY.....	10
4.0	AFM-505-3 DOWN POST MOUNT INSTALLATION .....	10
5.0	REMOVING THE AFM-505-3 DOWN POST MOUNT ASSEMBLY .....	13
6.0	AFM-505-50-1 DOVETAIL ADAPTER INSTALLATION (OPTIONAL).....	13
7.0	AFM-505-50-1 DOVETAIL ADAPTER REMOVAL (OPTIONAL).....	15
	APPENDIX A – AFM-505 CONFIGURATION AND ASSEMBLY INFORMATION .....	16
	APPENDIX B – METHOD OF ADDING ADDITIONAL SENSOR /CAMERA / PAYLOADS.....	18

## 1.0 INTRODUCTION AND DESCRIPTION

The Airfilm AFM-505 Utility Mounts allow for the attachment of utility equipment such as cameras, lights, and sensor instruments to be mounted on the Bell Helicopter Model 505 Helicopter. The single beam and downpost configuration can be installed on the left-hand side of the aircraft only. The AFM-505 Utility Mounts can be installed on both low and high skid models of the Bell 505. A table showing the configurations of the AFM-505 Utility Mount is shown below.

Table 1. AFM-505 Utility Mount Configuration Chart with Descriptions

Configuration	Part Number	Description
LH Nose Mount	AFM-505-1	Beam utility mount with payload mounted near the left-hand aircraft nose
LH Down Post	AFM-505-3	Left-hand belly mounted hardpoint with mounted payload.

The AFM-505-1 Nose Utility Mount System consists of a support beam that spans forward to aft. The mount attaches to the forward fuselage belly panel and forward landing gear cross tube. The Nose Utility Mount allows for the installation of a left-hand nose mounted payload.



Figure 1. AFM-505-1 Beam Installation on a Bell 505 Helicopter with Sample Payload Attached

The AFM-505-3 (LH) Down Post Mount System consists of a hardpoint mounted to the forward fuselage belly panel. The mount attaches to the fuselage using existing fuselage belly panel fasteners. The Down Post Mount allows for the installation of a payload directly under the hardpoint and can be installed on the left-hand side of the forward fuselage belly panel.



Figure 2. AFM-505-3 Downpost Installation on a Bell 505 Helicopter with Sample Payload Attached

After installation, calculate weight and balance for installed items and check for proper loading of aircraft. Antenna, lights, and additional installed equipment may need to be relocated to provide clearance for the camera mount system.

**Note** - If camera / sensor installations require additional power or system requirements beyond the placarded OEM auxiliary power outlet, additional certification(s) may be required.

## 2.0 AFM-505-1 LH NOSE UTILITY MOUNT INSTALLATION

### NOTES:

- a) The payload package for the installation is limited to a maximum allowable frontal area for 2.2 sq. ft and a weight of 125 lbs.
- b) When Airfilm payload Disconnect Devices (QDD-1-1 or DT-1-1) are installed, the payload can be removed and installed by crew.
- c) If camera/sensor installations require additional power or system requirements beyond the placarded OEM auxiliary power outlet, additional certification(s) may be required.
- d) Installation compatible with standard and high landing gear configurations and entry steps on the Bell 505 Helicopter. Ground Clearance when a payload is installed is not to be less than 6 inches from the ground when the aircraft is on a level surface.

2.1. Confirm that the mount will not interfere with any exterior kits, antennas, and other exterior mounted assemblies.

**AFM-505-10-1 BEAM ASSEMBLY INSTRUCTIONS:**

2.2. Attach the AFM-505-10-001 Fwd Main Beam to the AFM-505-10-003 Aft Main Beam and Aft Attachment Assembly using 4X AN6-34A Hex Bolts, 8X AN960-616 Washers, and 4X AN365-624 Locking Nuts.

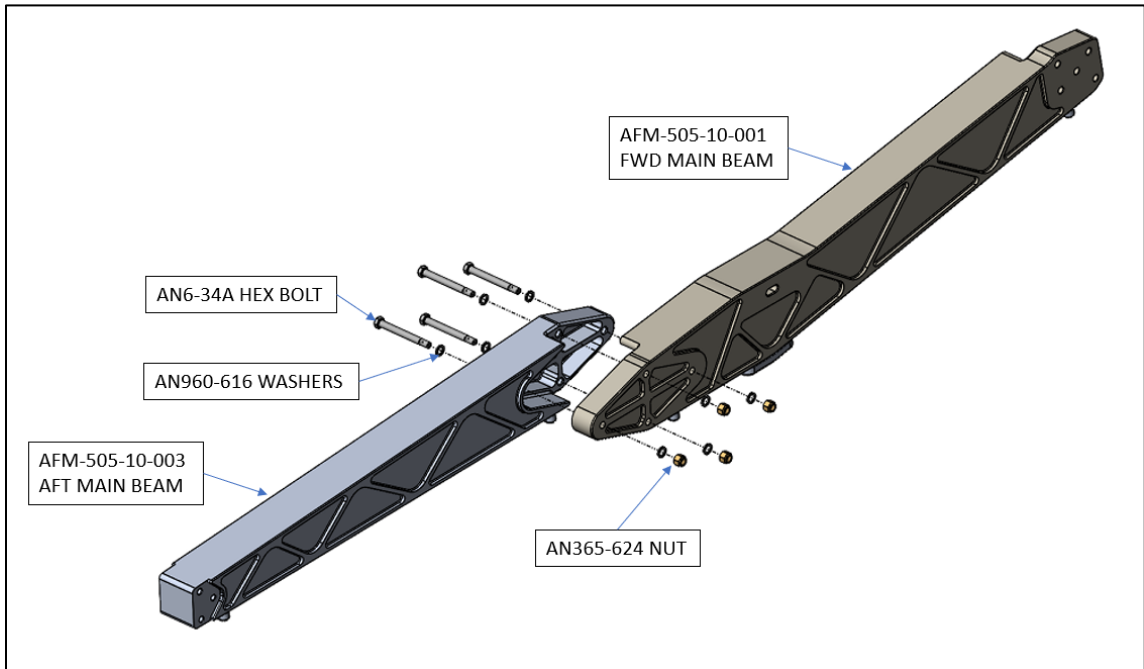

Figure 3. Assembly of the AFM-505-10-001 Fwd Main Beam to the AFM-505-10-003 Aft Main Beam.

2.3. Attach the assembled Beam to the AFM-505-30-1 Aft Attachment Assembly using 3X AN5-34A Bolts, 6X AN960-516 Washers, and 3X AN365-524 Locking Nuts.

**FEDERAL AVIATION ADMINISTRATION**  
Los Angeles ACO Branch  
**APPROVED**

Comment: FAA Approval of payload package installation limitations in Section 2.0

TSO/Project #: **ST17642LA-R**

Section: AIR-792                      Regulation: CFR

ver 1.0 (4-20)



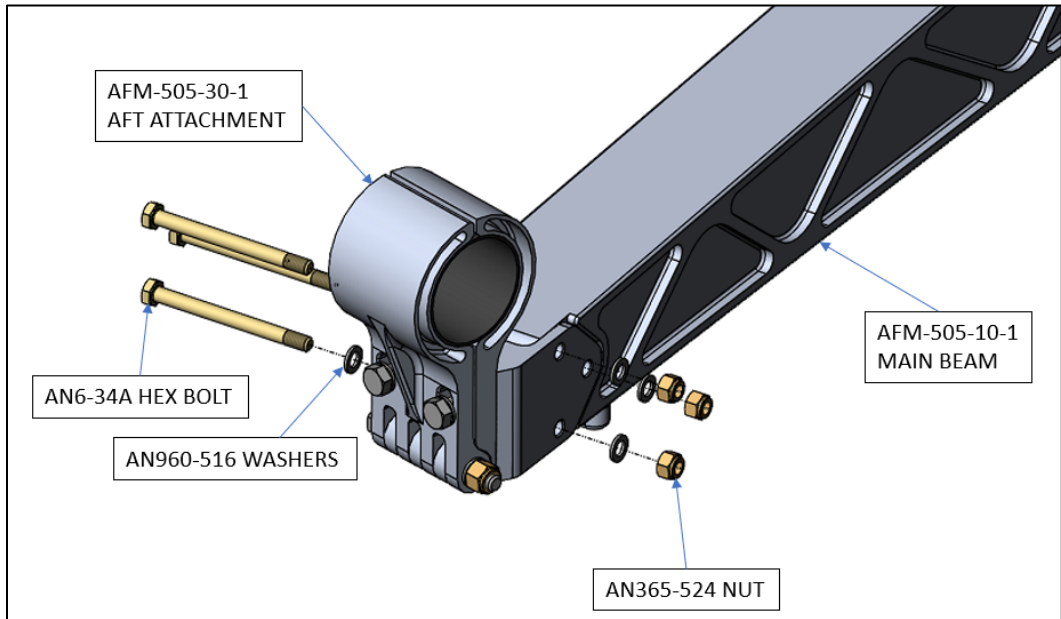

Figure 4. Assembly of the AFM-505-30-1 Aft Attachment Assembly onto the AFM-505-10-1 Main Beam

2.4. Attach the assembled Beam and Aft Mount to the AFM-505-40-1 Forward Arm Assembly using 5X AN6-34A Hex Bolts, 10X AN960-616 Washers, and 5X AN365-624 Locking Nuts.

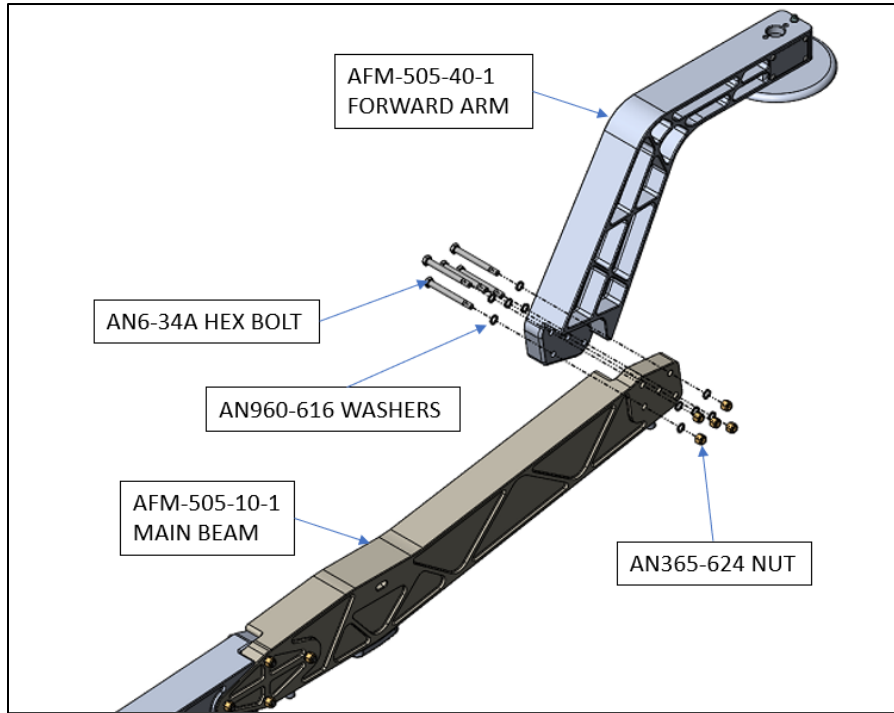

Figure 5. Installation of the Beam Assembly onto the AFM-505-40-1 Forward Arm Assembly.

### **FORWARD ATTACHMENT INSTALLATION:**

- 2.5. Remove the fasteners in the installation area of the forward attachment assembly. Refer to figure below for installation location and removed fasteners.

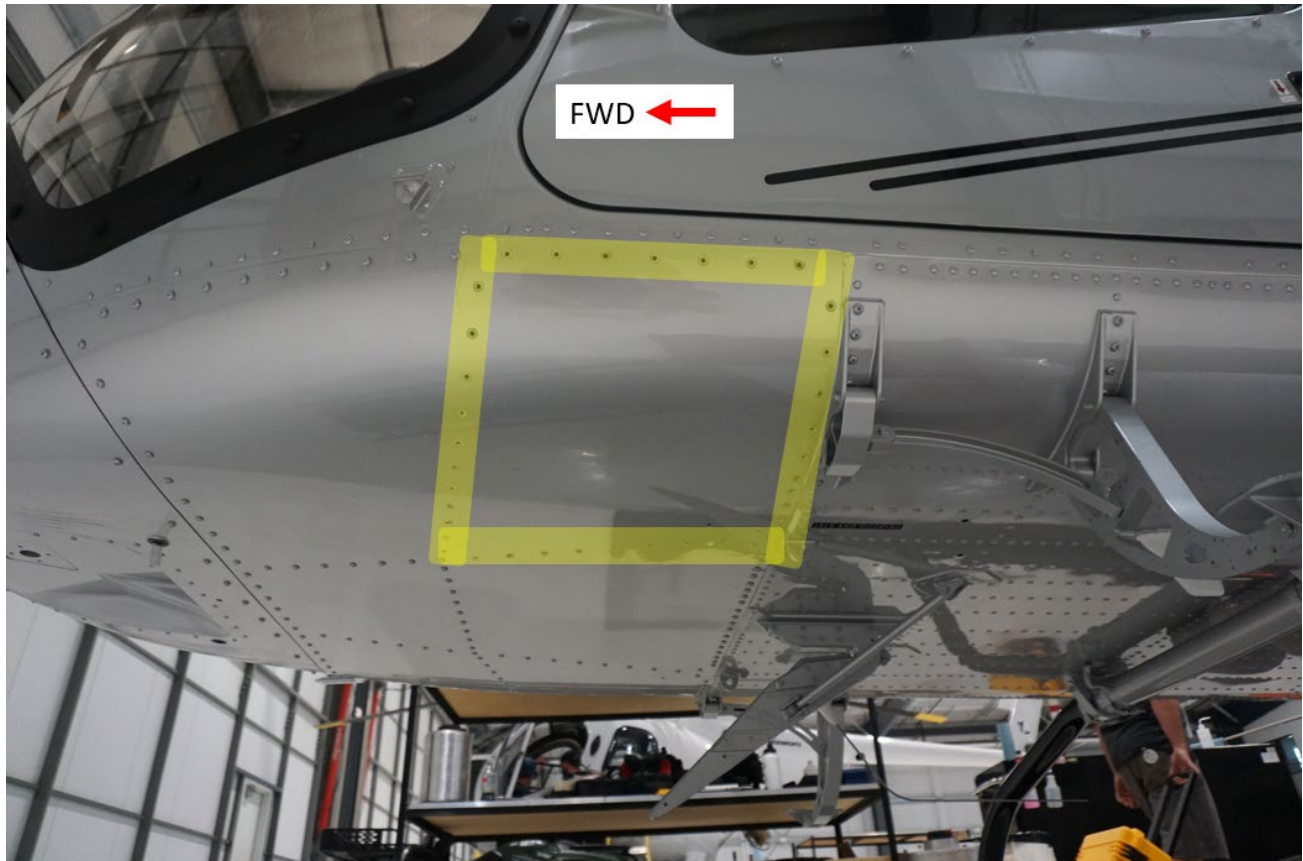

Figure 6. View Looking at Left-Hand Nose Section of the Bell 505 Fuselage, removed fasteners shown highlighted.

- 2.6. Use the supplied MS27039-0812 Screws and NAS1149FN0832P Washers to attach the Forward Attachment Assembly to the Aircraft Fuselage where shown. Ensure rubber gasket is installed on the faying surfaces between the Forward Attachment Assembly and Fuselage. Fasten all screws hand tight.

### **AFT ATTACHMENT AND MAIN BEAM INSTALLATION:**

- 2.7. Place the assembled Partially Assembled AFM-505-1 Beam under the fuselage. Identify the location on the forward landing gear cross tube where the aft clamping section of the Main Beam Assembly will attach. See the figure below for Aft Attachment location.



Figure 7. AFM-505-1 Aft Installation location on the Bell 505 Forward Landing Gear Cross Tube.

- 2.8. Detach the AFM-505-30-001 and AFM-505-30-003 Aft Half Clamps from the Beam Assembly for installation onto the forward landing gear cross tube. Remove the 2X AN6-14A Hex Bolts and 2X AN960-616 Washers to remove the Half Clamps.
- 2.9. Use the supplied AFM-505-RBKIT-1 Aft Rubber Shim Kit to provide a mounting surface for the Aft Half Clamps in the approximate installation area on the Landing Gear Cross Tube as shown in the figure above. Use the different shim thicknesses supplied in the Kit to obtain a proper clamp on the forward landing gear cross tube. Proper clamping force is obtained when the clamp is unable to shift or rotate when the AN6-14A Hex Bolts are attached to the Main Beam Assembly and fully torqued. Trim supplied shims as needed.
- 2.10. Clamp the AFM-505-30-001 and AFM-505-30-003 Aft Half Clamps over the Landing Gear Cross Tubes and installed rubber shims. Position the clamps approximately 5 inches from the inside face of the fuselage cross tube bracket. See figure 7 for installation details.



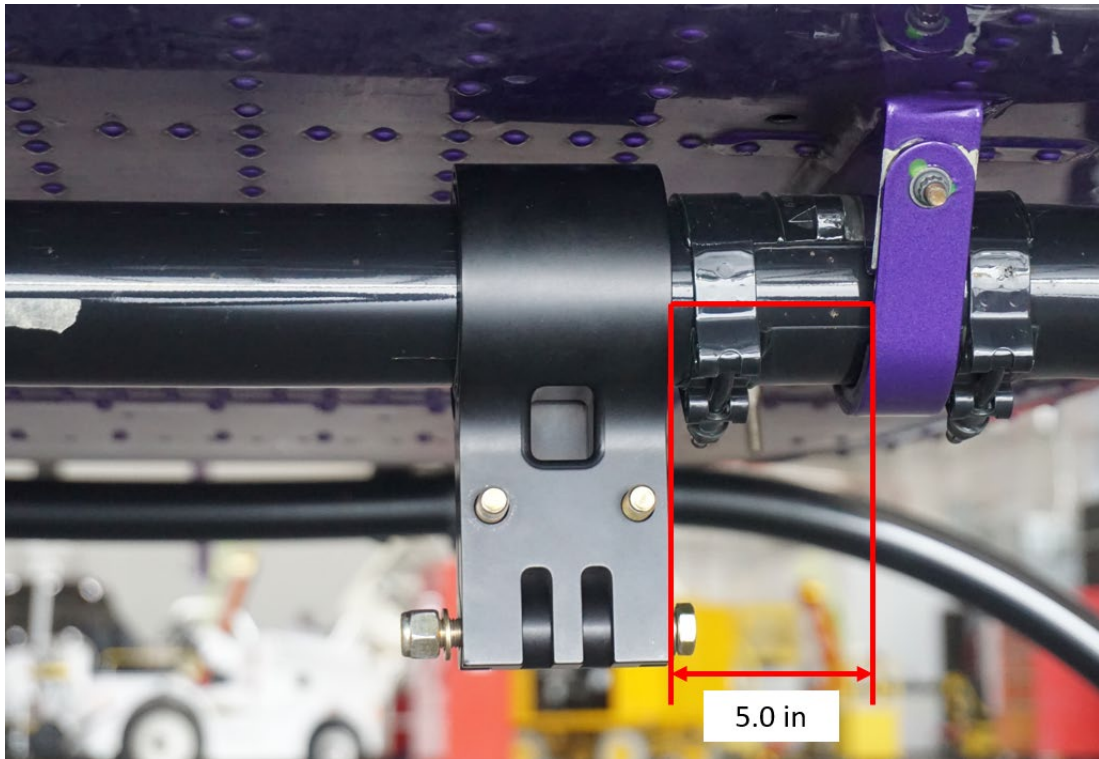

Figure 8. Clamp Location of the AFM-505-1 Aft Installation, Measured from the inside of the Cross Tube Bracket

- 2.11. Lift the aft end of the assembled main beam and attach it to the half clamps using the red anodized Aft Locking Hook (AFM-505-30-007) on the end of the beam. Once attached, secure the half clamps to the beam assembly using the two (2) supplied AN6-14A Hex Bolts and AN960-616 Washers. Secure bolts hand tight.
- 2.12. With the Aft Attachment clamps secure and hand tight, lift the forward portion of the beam assembly up to the AFM-505-20-007 Saddle plate on the installed Forward Attachment Assembly. Attach the Main Beam to the Saddle Plate using the supplied AN6-60A Hex Bolt, 2X AN960-616 Washers, and AN365-624 Locking Nut. Ensure the AFSP-2-21 Mount shims are captured between the AFM-505-20-007 Saddle Plate and the AFM-505-10-1 Main Beam Assembly.
- 2.13. Ensure no binding is present within the beam assembly. Check that all hardware is fully secured.

Torque all mount fasteners according to the table below. Torque values referenced per Bell Helicopter Technical Document BHT-ALL-SPM.

Table 2 – Torque Values – AFM-505-1 Nose Mount Installation

<b>Fastener Size/Type</b>	<b>Location</b>	<b>Torque Value</b>
AN6 Hex Bolt	Beam Assembly and Mounting Hardware	95 to 110 in-lb
MS27039 Screw	Forward Aircraft Attachment Hardware	7 to 9 in-lb
NAS1351-3 SHCS	Forward Attach Grid Plate Hardware	20 to 25 in-lb
NAS1351-4 SHCS	Forward Attach Grid Plate Hardware	50 to 70 in-lb

- 2.14. Ensure Aft Main Beam clamping attachment is secure and free of any movement between the clamp and cross tube. If movement exists, add thickness to the shims placed on the cross tube, torque hardware, and re-evaluate.



Figure 9. Installed View of the AFM-505-1 LH Nose Utility Mount

**WEIGHT AND BALANCE:**

2.15. Revise weight and balance per table shown below based on configuration.

The following table presents the location of the weight/center of gravity of the mount and payload sensor/camera for adjustment of the aircraft weight and center of gravity with the mount installed.

**NOTE:** Ground Clearance when a payload is installed is not to be less than 6 inches from the ground when the aircraft is on a level surface.

Table 3. Weight and Balance Information for AFM-505-1 Utility Mount (LH Beam Configuration)

<b>BELL 505 WEIGHT AND STATIONS - RH BEAM INSTALLATION</b>			
<b>FOR CAMERA / SENSOR SYSTEMS</b>			
<b>BELL MODEL 505</b>			
	WEIGHT	LONGITUDINAL	LATERAL
ITEM DESCRIPTION	LBS	ARM INCHES	ARM INCHES
<b>PAYLOAD LOCATION --USE CAMERA WEIGHT (125 lb max)*</b>			
<b>AFM-505-1 - MOUNT ASSEMBLY</b>	<b>55.00</b>	<b>80.90</b>	<b>20.30</b>
<b>QUICK DISCONNECT DEVICE (SELECT ONE OF THE FOLLOWING)</b>			
DT-1-1	2.40	80.90	29.50
TAPER FITTING ASSEMBLY (CF-10)	1.80	80.90	29.50
<b>*USE ACTUAL WEIGHT OF INSTALLED EQUIPMENT</b>			
Use proper weight and balance WHEN multiple configurations installed.			

Table 4. Example Calculation of Longitudinal and Lateral Moment using Weight and Balance Chart

<b>BELL 505 WEIGHT AND STATIONS - RH BEAM INSTALLATION</b>					
<b>FOR CAMERA / SENSOR SYSTEMS</b>					
<b>BELL MODEL 505</b>					
<b>EXAMPLE CALCULATION</b>					
	WEIGHT	LONGITUDINAL	LATERAL	Longitudinal	Lateral
ITEM DESCRIPTION	LBS	ARM INCHES	ARM INCHES	In-Lbs	In-Lbs
<b>125 lb payload, installed with a Dovetail, on the right side of the helicopter</b>					
<b>PAYLOAD LOCATION --USE CAMERA WEIGHT (125 lb max)*</b>	<b>125.00</b>	<b>45.24</b>	<b>-29.5</b>	<b>5655</b>	<b>-3687.5</b>
<b>AFM-505-1 - MOUNT ASSEMBLY</b>	<b>55.00</b>	<b>80.90</b>	<b>-20.3</b>	<b>4449.5</b>	<b>-1116.5</b>
<b>QUICK DISCONNECT DEVICE (SELECT ONE OF THE FOLLOWING)</b>					
DT-1-1	2.40	80.90	-29.5	194.16	-70.8
TAPER FITTING ASSEMBLY (CF-10)	N/A	80.90	-29.5	-	-
<b>Total</b>				<b>10298.66</b>	<b>-4874.8</b>

2.16. Install appropriate Placards in full view of pilot.

**Reduce published  $V_{NE}$  by 13 KIAS with a payload installed**

2.17. Make appropriate log book entry for installation.

2.18. Return to service.

### **3.0 REMOVING THE AFM-505-1 NOSE UTILITY MOUNT ASSEMBLY**

- 3.1. Remove entire AFM-505 Utility Mount Assembly and all associated hardware.
- 3.2. Install original hardware into the existing belly panel. Torque all hardware as required.
- 3.3. Calculate weight and balance.
- 3.4. Make appropriate log-book entry.
- 3.5. Return aircraft to service.

### **4.0 AFM-505-3 DOWN POST MOUNT INSTALLATION**

#### **NOTES:**

- a) The payload package for the installation is limited to a maximum allowable frontal area for 1.0 sq. ft and a weight of 50 lbs.
  - b) When Airfilm payload Disconnect Devices (QDD-1-1 or DT-1-1) are installed, the payload can be removed and installed by crew.
  - c) If camera/sensor installations require additional power or system requirements beyond the placarded OEM auxiliary power outlet, additional certification(s) may be required.
  - d) Installation compatible with standard and high landing gear configurations and entry steps on the Bell 505 Helicopter. Ground Clearance when a payload is installed is not to be less than 6 inches from the ground when the aircraft is on a level surface.
- 4.1. Confirm that the mount will not interfere with any exterior kits, antennas, and other exterior mounted assemblies.
  - 4.2. Remove the fasteners in the installation area of the forward attachment assembly. Refer to figure below for installation location and removed fasteners.







Figure 10. View Looking at Left-Hand Nose Section of the Bell 505 Fuselage, removed fasteners shown highlighted.

- 4.3. Use the supplied MS27039-0812 Screws and NAS1149FN0832P Washers to attach the Forward Attachment Assembly to the Aircraft Fuselage where shown. Ensure rubber gasket is installed on the faying surfaces between the Forward Attachment Assembly and Fuselage. Fasten all screws hand tight.
- 4.4. Reinstall the side belly panel along with the AFM-505-3 Down Post Mount Assembly. Install the supplied AFM-505-RBKIT-3 Rubber Shim between the Forward Attachment Assembly and aircraft skin and trim as needed. Use the supplied MS27039-0812 Screws and NAS1149FN0832P Washers to attach the Interface Plates and belly panel onto the aircraft. Reinstall original fasteners into the belly panel in holes not occupied by the Interface Plates. Fasten all screws hand tight.
- 4.5. Torque all mount fasteners according to the table below. Torque values referenced per Bell Helicopter Technical Document BHT-ALL-SPM.

Table 5. Torque Values – AFM-505-3 Down Post Installation

<b>Fastener Size/Type</b>	<b>Location</b>	<b>Torque Value</b>
MS27039 Screw	Forward Aircraft Attachment Hardware	7 to 9 in-lb
NAS1351-3 SHCS	Forward Attach Grid Plate Hardware	20 to 25 in-lb
NAS1351-4 SHCS	Forward Attach Grid Plate Hardware	50 to 70 in-lb



Figure 9. Installed AFM-505-3 Down Post Utility Mount, with Dummy Sensor for Reference.

4.6. Revise weight and balance per the tables shown below.

The following tables present the location of the weight/center of gravity of the mount and payload sensor/camera for adjustment of the aircraft weight and center of gravity with the mount installed.

**NOTE:** Ground Clearance when a payload is installed is not to be less than 6 inches from the ground when the aircraft is on a level surface.

Table 6. Weight and Balance Information for AFM-505-5 Utility Mount (LH Down Post Configuration)

<b>BELL 505 WEIGHT AND STATIONS - LH DOWN POST</b>			
<b>FOR CAMERA / SENSOR SYSTEMS</b>			
<i>BELL MODEL 505</i>			
ITEM DESCRIPTION	WEIGHT <b>LBS</b>	LONGITUDINAL <b>ARM INCHES</b>	LATERAL <b>ARM INCHES</b>
<b>AFM-505-3 PAYLOAD LOCATION -USE CAMERA WEIGHT (50 lb max)*</b>		<b>85.90</b>	<b>-18.00</b>
<b>AFM-505-3 - LH DOWN POST ASSEMBLY</b>	<b>10.50</b>	<b>85.90</b>	<b>-18.00</b>
<b>OPTIONAL QUICK DISCONNECT DEVICE (SELECT ONE OF THE FOLLOWING)</b>			
DT-1-1	<b>2.40</b>	<b>85.90</b>	<b>-18.00</b>
<b>*USE ACTUAL WEIGHT OF INSTALLED EQUIPMENT</b>			

4.7. Install appropriate Placards in full view of pilot.

**Reduce published  $V_{NE}$  by 13 KIAS with a payload installed**

- 4.8. Make appropriate log book entry for installation.
- 4.9. Return to service.

**5.0 REMOVING THE AFM-505-3 DOWN POST MOUNT ASSEMBLY**

- 5.1. Remove entire AFM-505-3 Down Post Mount Assembly and all associated hardware.
- 5.2. Install original hardware into the existing belly panel. Torque all hardware as required.
- 5.3. Calculate weight and balance.
- 5.4. Make appropriate log-book entry.
- 5.5. Return aircraft to service.

**6.0 AFM-505-50-1 DOVETAIL ADAPTER INSTALLATION (OPTIONAL)**

- 6.1. Locate the Dovetail Adapter mounting holes at the connection of the two AFM-505 Beam Halves. Remove the existing NAS1351 Screws from the forward and aft mounting points, along with the Skid Pads fastened by the screws. Refer to the figure below for the mounting location.

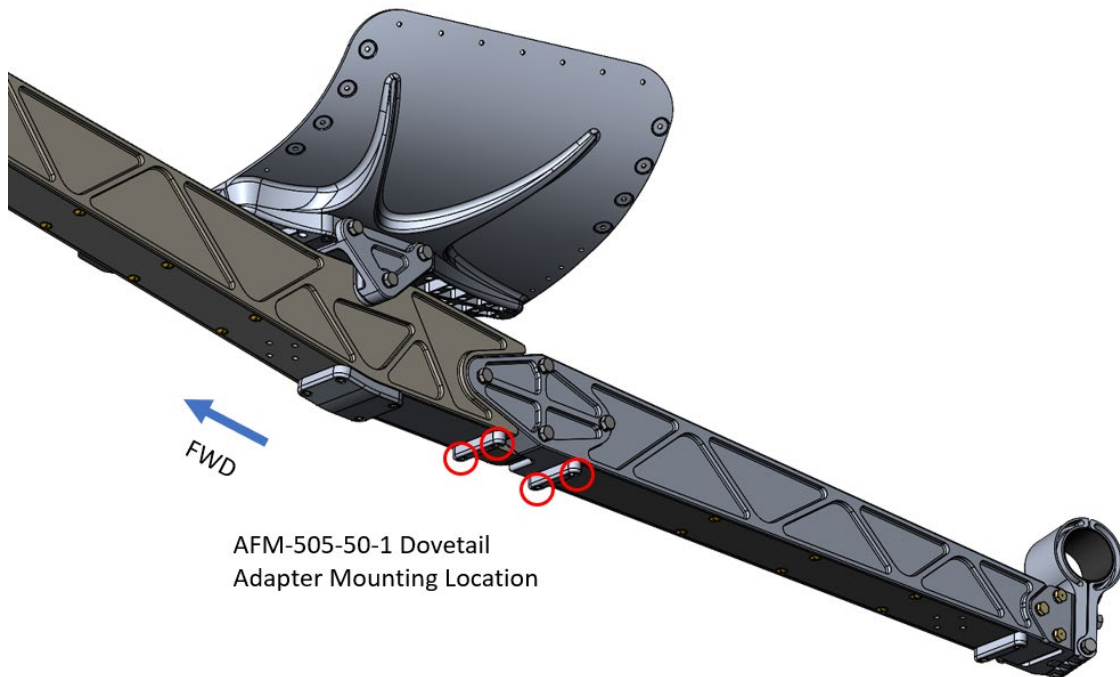

Figure 11. Mounting Location of the AFM-505-50-1 Dovetail Adapter

- 6.2. Mount the AFM-505-50-1 Dovetail Adapter to the Main Beam using 4X AN4-6A hex bolts and AN960 Washers (Alt: 4X MS20004-4 Screws may be substituted).

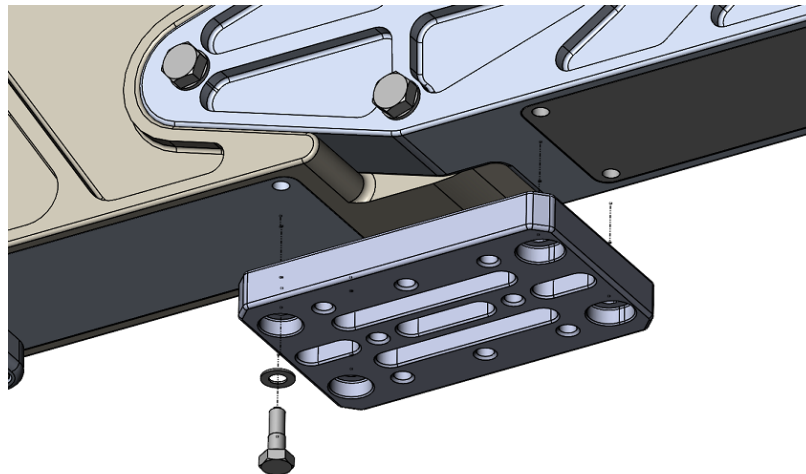

Figure 12. Mounting of the AFM-505-50-1 Dovetail Adapter to the Main Beam

- 6.3. Torque all adapter fasteners per Table 2 and BHT-ALL-SPM. Check that all hardware is fully secured.



## **7.0 AFM-505-50-1 DOVETAIL ADAPTER REMOVAL (OPTIONAL)**

- 7.1. Remove the fasteners securing the Dovetail Adapter to the Main Beam (AN4-6A or MS20004-4) and set aside.
- 7.2. Reattach the Small Skid Pads and NAS1351 Socket Head Cap Screws provided with the Main Beam Assembly.
- 7.3. Torque all adapter fasteners per Table 2 and BHT-ALL-SPM. Check that all hardware is fully secured.

## APPENDIX A – AFM-505 CONFIGURATION AND ASSEMBLY INFORMATION

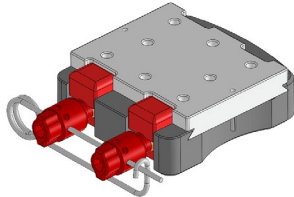

**DT-1-1**  
 DOVE TAIL

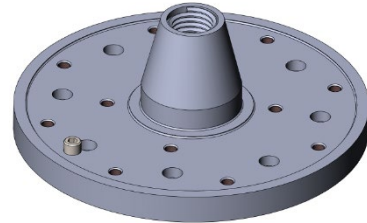

**CF-10**  
 MALE TAPER ADAPTER

### AFM-505 PAYLOAD ATTACHMENT IDENTIFICATION

P/N	DESCRIPTION	QTY	FASTENERS	
DT-1-1	DOVETAIL	4	MS20004-4	SHCS
CF-10	MALE TAPER ADAPTER	1	CF-112	BOLT, SPECIAL
			98023A038	WASHER
			CF-113	TEFLON WASHER
			MS20995C32	SAFETY WIRE (.032")

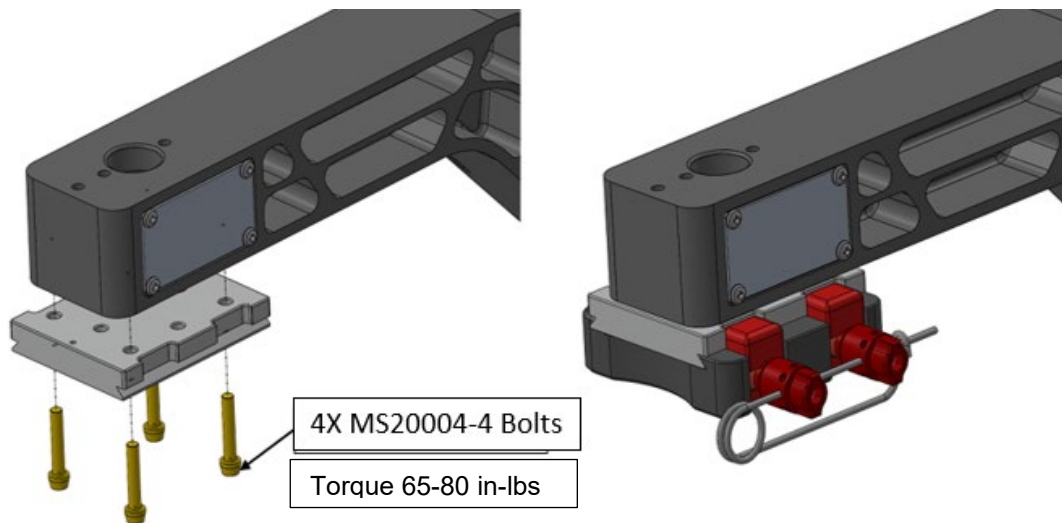

Figure 13. Installation of the DT-1-1 Dovetail onto the AFM-505 Utility Mount

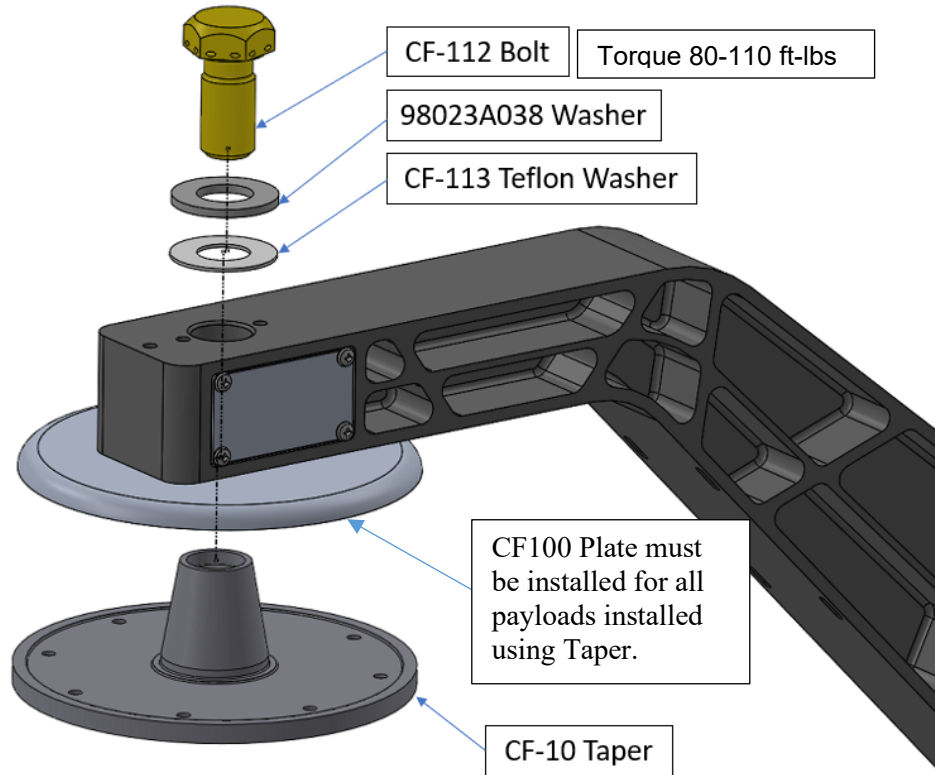

Figure 14. Installation of the CF-10 Taper onto the AFM-505 Utility Mount (Safety Wire not shown)

## APPENDIX B – METHOD OF ADDING ADDITIONAL SENSOR /CAMERA / PAYLOADS

### 3.1 Overview

This Appendix provides the requirements necessary to qualify sensor / camera / light payloads – IF NEEDED.

It may also be used as a check list for previously approved sensor /cameras / light payloads if desired.

The STC flight testing was conducted and the STC approved with the largest and heaviest payload expected for use with this mount. The specific sensor/cameras/light not listed in the installation manual of equal or lesser than the limit case are accepted with this follow-on test plan.

### 3.2 Sensor/ Camera/ payload

Make & Model \_\_\_\_\_

### 3.3 Test Team

### 3.4 Pilot(s)

\_\_\_\_\_  
Print Name

### 3.5 Mechanic and/or Engineer and/or Camera Operator

\_\_\_\_\_  
Print Name



Test Aircraft Configuration and Location

**3.6 Aircraft Model, Registration & Serial Number**

Model \_\_\_\_\_ Registration Number \_\_\_\_\_ Serial Number \_\_\_\_\_

**3.7 Test Configurations**

Empty weight with appropriate fuel and camera system installed

Takeoff Gross weight with crew

<b>Configuration</b>	<b>Gross Weight</b>	<b>Longitudinal CG</b>	<b>Lateral CG</b>
Empty Wt			
Takeoff Wt			

A.1.1. Test Location

\_\_\_\_\_  
 Airport or Test Site

Test Conditions

Date: \_\_\_\_\_

Weather: Ceiling \_\_\_\_\_ Visibility \_\_\_\_\_ Winds \_\_\_\_\_

Altimeter \_\_\_\_\_ Field Elevation \_\_\_\_\_

Flight Time: Engine Start \_\_\_\_\_ Shut Down \_\_\_\_\_ Flt Time \_\_\_\_\_

Flight Test

A.1.2. Overview

Applicable regulations demonstrated for compliance are indicated with the following symbol ➔. The testing required for the compliance findings of this installation will be made by as a subject/qualitative evaluation. Although the most critical CG is at the aft limit for most tests this configuration is mounted forward of the mast should not approach the aft limits. This also depends on crew loading. The test team conducts the following tests and evaluations and mark initial the box at the end of each section if the configuration successfully passes the requirements.

A.1.3. FAR § 27.51 Takeoff

**A.1.3.1. Applicable Regulation**

- ➔(a) The takeoff data required by Secs. 27.53, 27.55, 27.59, 27.60, 27.61, 27.62, 27.63, and 27.67 must be determined--
  - (1) At each weight, altitude, and temperature selected by the applicant; and
  - (2) With the operating engines within approved operating limitations.
- ➔ (b) Takeoff data must--
  - (1) Be determined on a smooth, dry, hard surface; and
  - (2) Be corrected to assume a level takeoff surface.
- (c) No takeoff made to determine the data required by this section may require exceptional piloting skill or alertness, or exceptionally favorable conditions.

**A.1.3.2. Method of Compliance**

The recommended takeoff procedure must be demonstrated to remain clear of the HV "avoid" areas without requiring exceptional piloting skill or exceptionally favorable conditions.

A qualitative evaluation of the ability to safely land at any point along the flight path will be made using judgment and experience with the basic aircraft. No engine failure testing at low altitude will be conducted.

The normal takeoff procedures will be used for the sensor/camera/light payload and mount installation.

**A.1.3.3. Findings**

Satisfactory \_\_\_\_\_

**A.1.4. FAR § 27.71 Glide Performance**

**A.1.4.1. Applicable Regulation**

- ➔For each category B helicopter, except multiengine helicopters meeting the requirements of Sec. 27.67(b) and the powerplant installation requirements of category A, the steady angle of glide must be determined in autorotation--
  - (a) At the forward speed for minimum rate of descent as selected by the applicant;
  - ➔ (b) At the forward speed for best glide angle;
  - (c) At maximum weight; and
  - ➔ (d) At the rotor speed or speeds selected by the applicant

**A.1.4.2. Method of Compliance**

(1) Performance capabilities during stabilized autorotative descent are useful pilot tools to assist in the management of a Category B rotorcraft when all engines fail. This information is also useful in determining the suitability of available landing areas along a given route segment.

(2) Two speeds are of particular importance, the speed for minimum rate of descent and the speed for best angle of glide. These speeds along with glide distance information are required as flight manual entries per FAR § 27.1587. The recommended speed for autorotation is usually optimized to assure an effective flare capability and yet be slow enough to allow a controlled, relatively slow touchdown condition. Recommended autorotation speed is ordinarily between the minimum rate of descent and maximum glide angle speeds.

An autorotative descent starting at least 1000 feet above the ground and at the speed published in the RFM, 100% RPM value will be demonstrated. Small turns will be conducted in the descent. The maneuver will be terminated with power at a safe altitude.

The aircraft should be easily controllable and the difference between the mount and camera/sensor/light payload and the clean configuration is the evaluation point.

**A.1.4.3. Findings**

Satisfactory \_\_\_\_\_ Altitude Band HP \_\_\_\_\_ Fuel Gage Reading \_\_\_\_\_

**A.1.5. FAR § 27.143 Controllability and Maneuverability**

**A.1.5.1. Applicable Regulation**

- ➔(a) The rotorcraft must be safely controllable and maneuverable -
  - ➔ (1) During steady flight; and
  - ➔(2) During any maneuver appropriate to the type, including -
    - ➔ (i) Takeoff;
    - ➔ (ii) Climb;
    - ➔ (iii) Level flight;
    - ➔ (iv) Turning flight;
    - ➔ (v) Glide
    - ➔ (vi) Landing (power on and power off);
- ➔(b) The margin of cyclic control must allow satisfactory roll and pitch control at VNE with -
  - (1) Critical weight;
  - (2) Critical center of gravity;
  - (3) Critical rotor rpm; and
  - (4) Power off (except for helicopters demonstrating compliance with paragraph (f) of this section) and power on.

(c) A wind velocity of not less than 17 knots must be established in which the rotorcraft can be operated without loss of control on or near the ground in any maneuver appropriate to the type (such as crosswind takeoffs, sideward flight, and rearward flight), with -

- (1) Critical weight;
- (2) Critical center of gravity;
- (3) Critical rotor rpm; and

(4) Altitude, from standard sea level conditions to the maximum altitude capability of the rotorcraft or 7,000 feet, whichever is less.

(d) The rotorcraft, after failure of one engine in the case of multiengine rotorcraft that meet Transport Category A engine isolation requirements, or complete engine failure in the case of other rotorcraft, must be controllable over the range of speeds and altitudes for which certification is requested when such power failure occurs with maximum continuous power and critical weight. No corrective action time delay for any condition following power failure may be less than -

(1) For the cruise condition, one second, or normal pilot reaction time (whichever is greater); and

(2) For any other condition, normal pilot reaction time.

(e) For helicopters for which a VNE (power off) is established under § 27.1505(c), compliance must be demonstrated with the following requirements with critical weight, critical center of gravity, and critical rotor rpm:

(1) The helicopter must be safely slowed to VNE (power off), without exceptional pilot skill, after the last operating engine is made inoperative at power on VNE.

(2) At a speed of 1.1 VNE (power off), the margin of cyclic control must allow satisfactory roll and pitch control with power off.

#### **A.1.5.2. Method of Compliance**

The general requirements for control and for maneuverability are summarized in section (a) of the AC, which is largely self-explanatory.

Section (b) specifies flight at  $V_{NE}$  with critical weight, center of gravity (CG), rotor RPM, and power. Adequate cyclic authority must remain at  $V_{NE}$  for nose down pitching of the rotorcraft and for adequate roll control.

The helicopter will be flown between 1000 and 3000 feet above ground. The test altitude will be dependent on traffic and terrain and conditions close to sea level pressure are desirable.  $V_{NE}$  will be the value stated in the RFM for the test density altitude.

Qualitative measurement techniques (pilot opinion) will be used. The tests will include:

Takeoff

Climbing flight

Forward flight to  $V_{NE}$ , not more than the published RFM limit at MCP (maybe less than MCP)

Left & right 30 degree bank turns at  $V_{NE}$  and at MCP (maybe less than MCP)

Take-off & Landings (Power **on** only).

The aircraft should be easily controllable and adequate cyclic margins should exist throughout the flight test points. The difference between the mount and sensor / camera / light payload and the clean configuration is the evaluation point.

**A.1.5.3. Findings**

Satisfactory \_\_\_\_\_ Cruise Altitude HP \_\_\_\_\_ Fuel Gage Reading \_\_\_\_\_

A.1.6. FAR § 27.171 Stability: General

**A.1.6.1. Applicable Regulation**

➔The rotorcraft must be able to be flown, without undue pilot fatigue or strain, in any normal maneuver for a period of time as long as that expected in normal operation. At least three landings and takeoffs must be made during this demonstration.

**A.1.6.2. Method of Compliance**

Compliance with the requirements of this section can often be obtained for the VFR condition without any specific or designated flight testing. Demonstrate that the aircraft can be satisfactorily flown throughout the maximum endurance capabilities of the rotorcraft including night and turbulence conditions if those are critical. This test should be conducted with minimum required systems in the aircraft and with minimum flight crew.

Compliance for this requirement will be evaluated throughout the test program.

**A.1.6.3. Findings**

Satisfactory \_\_\_\_\_

A.1.7. FAR § 27.251 Vibration

**A.1.7.1. Applicable Regulation**

➔Each part of the rotorcraft must be free from excessive vibration under each appropriate speed and power condition.

**A.1.7.2. Method of Compliance**

This flight requirement may be both a qualitative and quantitative flight evaluation. Section 27.571(a) contains the flight load survey requirement that results in accumulation of vibration quantitative data. Section 27.629 generally requires quantitative data to show freedom from flutter for each part of the rotorcraft including control or stabilizing surfaces and rotors.



The aircraft should have a good track & balance for this evaluation. The airspeed should be evaluated at 20 kt increments out to the RFM VNE speed. Variations in rotor RPM expected in normal flight should be evaluated. Changes in vibration are best sensed in the cyclic and pedal controls. The stability of the camera/sensor image will be a good indicator.

The pilot will make a subjective evaluation of the difference between the mount and sensor / camera/ light payload and the clean configuration is the evaluation point.

Compliance with this requirement will be evaluated during testing of FAR §27.143 Controllability and Maneuverability.

**A.1.7.3. Findings**

Satisfactory \_\_\_\_\_

A.1.8. FAR § 27.773 Pilot Compartment View

**A.1.8.1. Applicable Regulation**

- (a) Nonprecipitation conditions. For nonprecipitation conditions, the following apply:
- ➔ (1) Each pilot compartment must be arranged to give the pilots a sufficiently extensive, clear, and undistorted view for safe operation.
  - ➔ (2) Each pilot compartment must be free of glare and reflection that could interfere with the pilot's view. If certification for night operation is requested, this must be shown by night flight tests.
- (b) Precipitation conditions. For precipitation conditions, the following apply:
- (1) Each pilot must have a sufficiently extensive view for safe operation—
    - (i) In heavy rain at forward speeds up to VH; and
    - (ii) In the most severe icing condition for which certification is requested.
  - (2) The pilots must have a window that—
    - (i) Is openable under the conditions prescribed in subparagraph (1) of this paragraph; and
    - (ii) Provides the view prescribed in that subparagraph.

**A.1.8.2. Method of Compliance**

The section outlines requirements for pilot view in fairly general terms. The aircraft was approved with the installed glareshield and instrument panel that meet the rules. Any additional equipment/monitors must be positioned so as not to limit or obstruct the pilot's field of view. There will be some cases where the installation will be temporary and for a unique mission and consideration should be given for these limited cases and time.

If night operations are expected with an operational system, a "dark cockpit" or night evaluation will be necessary to insure the glare/reflection will not interfere with the pilot duties. A limitation to the use at night is an option.

**A.1.8.3. Findings**

Satisfactory \_\_\_\_\_

A.1.9. FAR § 27.787 Cargo & Baggage Compartment

**A.1.9.1. Applicable Regulation**

Cargo and baggage compartments.

(a) Each cargo and baggage compartment must be designed for its placarded maximum weight of contents and for the critical load distributions at the appropriate maximum load factors corresponding to the specified flight and ground load conditions, except the emergency landing conditions of Sec. 27.561.

(b) There must be means to prevent the contents of any compartment from becoming a hazard by shifting under the loads specified in paragraph (a) of this section.

➔ [(c) Under the emergency landing conditions of Sec. 27.561, cargo and baggage compartments must--

(1) Be positioned so that if the contents break loose they are unlikely to cause injury to the occupants or restrict any of the escape facilities provided for use after an emergency landing; or

(2) Have sufficient strength to withstand the conditions specified in Sec. 27.561 including the means of restraint, and their attachments, required for the maximum authorized weight of cargo and baggage at the critical loading distribution.]

(d) If cargo compartment lamps are installed, each lamp must be installed so as to prevent contact between lamp bulb and cargo.

**A.1.9.2. Method of Compliance**

Amendment 27-31 adds two subparagraphs to § 27.787(c) which clarifies that cargo and baggage compartments should be designed to protect occupants from injury by the compartment contents during emergency landings. This may be done by location or by retention provisions.

The sensor/camera/light controllers and power supply must be located and secured in a position that will not endanger occupants in an emergency landing impact.

Consideration should be given to stowage and egress when filming in hovering flight. In some cases, this might not be possible.

**A.1.9.3. Findings**

Comment: \_\_\_\_\_

Satisfactory \_\_\_\_\_

A.1.10. FAR § 27.1301 Function and Installation.

**A.1.10.1. Applicable Regulation**

Each item of installed equipment must--

- ➔ (a) Be of a kind and design appropriate to its intended function
- (b) Be labeled as to its identification, function, or operating limitations, or any applicable combination of these factors;
- (c) Be installed according to limitations specified for that equipment; and
- ➔ (d) Function properly when installed.

**A.1.10.2. Method of Compliance**

For optional equipment, the emphasis on functioning is rather limited compared to that for required equipment. The conditions under which the optional equipment is evaluated should be recorded in the report. The major emphasis for this type of equipment should be to ensure it does not interfere with the operation of systems that are required for safe operation of the rotorcraft, and that the failure modes are acceptable and do not create any hazards.

During flight operations, operate all avionics and electrical systems. Complete the matrix below. The matrix is laid out with the newly installed equipment listed at the top of the page and all aircraft systems listed down the left side of the page. Note any EMI or RFI either TO or FROM the installed equipment. Note any anomalies or EMI/RFI interference to other instruments or indications during all testing phases of flight.

Each item must be checked. Check off each block if no interference is noted. If interference is present during the test, DO NOT CHECK THE BOX and explain in Comments section at end of section. If applicable, note relevant conditions (i.e. frequencies, OBI selection, function modes) under which the interference occurred.

**A.1.10.3. Findings**

<b>Interference?</b>		<b>Camera/Sensor/Light</b>	<b>Position Controller</b>
Camera/Sensor/Light			
Position Controller			
VHF Comm 1			
VHF Comm 2			
VHF Comm 3			
VHF NAV 1			
VHF NAV 2			
ADF 1			
XPONDER 1			
Other Radios			
Audio 1			
Audio 2			
Standby Compass			
Engine Inst			
Fuel Gage			
Clock			
Voltmeter			
Ammeter			
Other			

<b>EMI / RFI Comments:</b>

Satisfactory \_\_\_\_\_



**Signatures**

General test findings \_\_\_\_\_

Pilot Signature \_\_\_\_\_

Mechanic/ Engineer \_\_\_\_\_

Other Flt Personnel Signature & Function

\_\_\_\_\_