

TYPICAL INSTALLATION SPECIFICATIONS

STRUCTURAL LIMITATIONS:
 MAX WEIGHT = 122 LBS (55.3 Kg)(1G, Z DIR)
 LIMIT LOAD FACTOR (Nz) = 3.5
 MAX DRAG MOMENT (My) = 1334 IN-LBS
 DT-1-1/DT-1-1A W/ DT-1-11 WEIGHT = 2.4 LBS (1.5 Kg)

- Installation of DT-1-11 (UPPER DOVETAIL) and DT-1-1 OR DT-1-1A (LOWER DOVETAIL)
- Carefully align upper and lower plate
 - Slide lower dovetail until locking teeth are aligned with corresponding teeth in upper dovetail
 - Hand tighten teeth by turning knobs clockwise, max torque 50 inch pounds
 - For limited access for tightening, the knobs have 5/16th allen key recess
 - Align knob through holes to allow installation of safety pin
 - Ensure safety pin locked
 - Ensure that no free play or movement exist between the payload and the aircraft mount and dovetail plates.

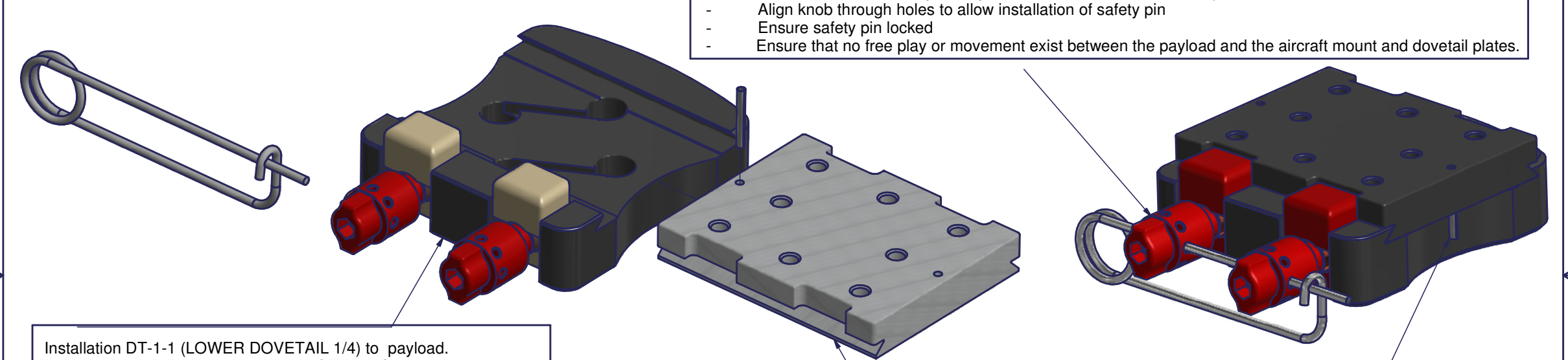
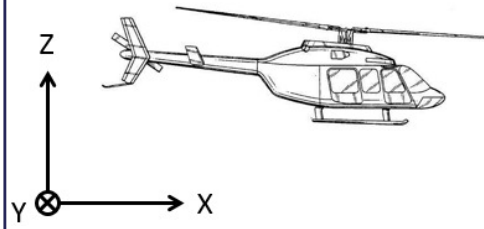

Installation DT-1-1 (LOWER DOVETAIL 1/4) to payload.
 Install lower dovetail to payload using QTY 4 MS20004-X (Length as required) or eqvl bolts into payload /sensor. Insure that bolts are tightened to proper torque and safety requirements (see payload requirements from sensor manufacturer)

Installation DT-1-1A (LOWER DOVETAIL 5/16) to payload.
 Install lower dovetail to payload using QTY 4 MS20005-X (Length as required) / or eqvl bolts into payload /sensor. Insure that bolts are tightened to proper torque and safety requirements (see payload requirements from sensor manufacturer)

Installation DT-1-11 (UPPER DOVETAIL) to aircraft mount.
 Install upper dovetail to airframe using minimum of 4 AN 4-XXA (length as required) (OR EQVL BOLTS) , AN960-416 washer and MS21042-4 Stop Nuts or equivalent hardware as required. Upper dovetail has multiple through holes to accommodate various bolt patterns

NOTE: SPRING PIN (INSTALLED) ASSURES ONE DIRECTIONAL LOADING IF REQUIRED.

- ORDER INFORMATION:**
- DT-1-1 / DT-1-11: DOVETAIL SET COMPLETE (1/4 LOWER ATTACHMENT)
 - DT-1-1A / DT-1-11: DOVETAIL SET COMPLETE (5/16 LOWER ATTACHMENT)
 - DT-1-1: DOVETAIL LOWER (1/4 LOWER ATTACHMENT)
 - DT-1-1A: DOVETAIL LOWER (5/16 LOWER ATTACHMENT)
 - DT-1-11 DOVETAIL UPPER

WARNING:
SAFETY PIN MUST BE INSTALLED AND LOCKED PRIOR TO FLIGHT.

AirFilm Camera Systems Georgetown, Ca 530-333-0193 www.airfilm.com	
TITLE DOVE TAIL QUICK RELEASE INSTALL & ORDER INFO	
DWG NO DT_1	REV G
SHEET 1 OF 1	