

DOCUMENT AF412NM-008

INSTRUCTIONS FOR CONTINUED AIRWORTHINESS

AF412NM-1 NOSE MOUNT
FOR THE
BELL MODEL 212, 412, 412EP AND 412CF
AND
AGUSTA BELL MODEL AB412 AND AB412EP ROTORCRAFT



AIRFILM CAMERA SYSTEMS
6245 AERODROME WAY
HANGAR NO. 2
GEORGETOWN, CA

**AIRFILM CAMERA SYSTEMS
MAINTENANCE INSTRUCTIONS
DOCUMENT No. AF412NM-008**

RECORD OF REVISIONS

No.	Date	By	DESCRIPTION
N/C	4-15-10	JCF	Original release
1			
2			
3			
4			
5			
6			
7			

LIST OF EFFECTIVE PAGES

All pages contained herein are at latest revision shown in Log of Revisions.	
LIST OF EFFECTIVE PAGES	1 – 8

**AIRFILM CAMERA SYSTEMS
MAINTENANCE INSTRUCTIONS
DOCUMENT No. AF412NM-008**

TABLE OF CONTENTS

SECTION	TITLE	PAGE
	RECORD OF REVISIONS	1
	TABLE OF CONTENTS	2
1.1	INTRODUCTION	3
1.2	PURPOSE	3
1.3	SCOPE	3
1.4	APPLICABILITY	3
1.5	DOCUMENT CHANGE CONTROL.....	3
1.6	SPECIAL TOOLS.....	3
2.0	AIRWORTHINESS LIMITATIONS	3
3.0	INSPECTION REQUIREMENTS	4
3.1	SCHEDULED INSPECTIONS	6
3.1.1	100 HOUR INSPECTION INTERVALS.....	6
	TABLE 3.1.1 100 HOUR TIME IN SERVICE INSPECTIONS ON HELICOPTER	6
3.2	1000 HOUR TIME IN SERVICE INSPECTION INTERVAL.....	6
	TABLE 3.2.1 COMPONENT INSPECTIONS.....	6
3.3	SPECIAL INSPECTIONS	7
3.4	INSPECTION LIMITS	7
4.0	REMOVAL, DISASSEMBLY, REASSEMBLY AND INSTALLATION.....	7
4.1	INSTALLATION.....	7
4.2	REMOVAL.....	8
5.0	WEIGHT AND BALANCE.....	8

**AIRFILM CAMERA SYSTEMS
MAINTENANCE INSTRUCTIONS
DOCUMENT No. AF412NM-008**

1.0 GENERAL

1.1 INTRODUCTION

This manual presents the Maintenance Instructions for the installation of the Airfilm Camera Systems model AF412NM-1 Nose Utility Mount for the Bell 212 and 412 series rotorcraft. The mount is designed to facilitate the attachment of equipment such as video cameras and infrared sensors. The cover page of this document shows the typical mount installation.

1.2 PURPOSE

The purpose of this document is to provide Maintenance Instructions to inspect the Airfilm Camera Systems Model AF412NM-1 Nose Utility Mount.

1.3 SCOPE

The scope of this document is limited to information, procedures, requirements and limitations for this Supplemental Type Certificate. When a requirement specified in the appendix to the regulations is not applicable to this Supplemental Type Certificate the requirement will not be included in the Maintenance Instructions.

1.4 APPLICABILITY

These Maintenance Instructions are applicable to the Airfilm Camera Systems AF412NM-1 Nose Utility Mount.

1.5 DOCUMENT CHANGE CONTROL

Changes to this document will be distributed to registered owners of the AF412NM-1 Nose Utility Mount within 10 days after the revision is approved. Changes to this document will be indicated by a revision number in the footer, vertical lines adjacent to the change, and in the Record of Revisions.

1.6 SPECIAL TOOLS

No special tools are required for maintenance of this appliance

2.0 AIRWORTHINESS LIMITATIONS

NO LIFE LIMITED COMPONENTS ARE AFFECTED

**AIRFILM CAMERA SYSTEMS
MAINTENANCE INSTRUCTIONS
DOCUMENT No. AF412NM-008**

3.0 INSPECTION REQUIREMENTS

FIGURE 3.1 AF412NM-1 NOSE UTILITY MOUNT.



PARTS LIST

ITEM	-1A	-1B	-1C	PART NUMBER	DESCRIPTION
1	1	1	1	AF412NM-5	BASE PLATE BRACKET
2	0	0	1	AF412NM-10	16 DEG ANGLE BRACKET LARGE ASSY
3	0	1	0	AF412NM-20	16 DEG ANGLE BRACKET SMALL ASSY
4	0	6	8	AN960-416L	WASHER THIN
5	0	6	8	AN4-5A ALTERNATE MS16998-43 ALTERNATE MS2004-10	HEX BOLT CAP SCREW INTERNAL WRENCHING SCREW
6	2	2	2	AF412NM-30	DOUBLER, SHIM
7	8	8	8	MS21059-4	NUTPLATE
8	16	16	16	MS20426AD3	RIVET
9	4	4	4	AN4-10A	HEX BOLT
10	4	4	4	AN960-416	WASHER

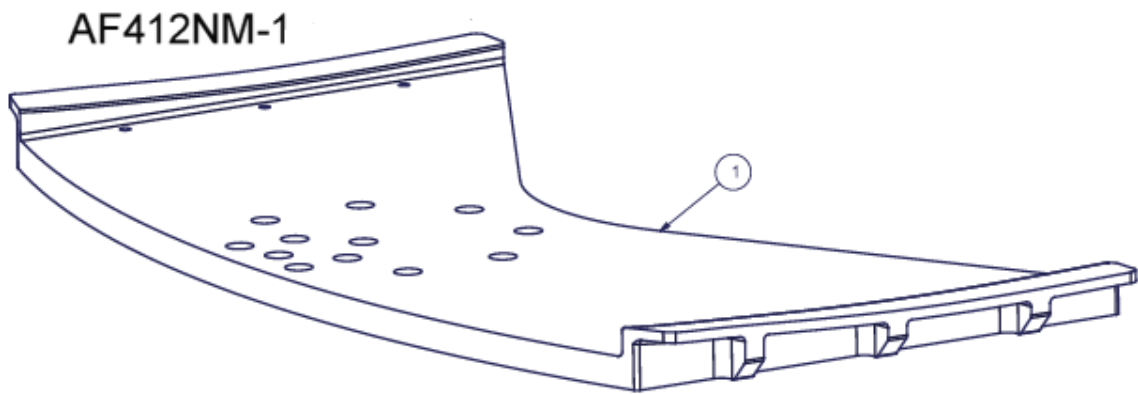

AIRFILM CAMERA SYSTEMS
MAINTENANCE INSTRUCTIONS
DOCUMENT No. AF412NM-008

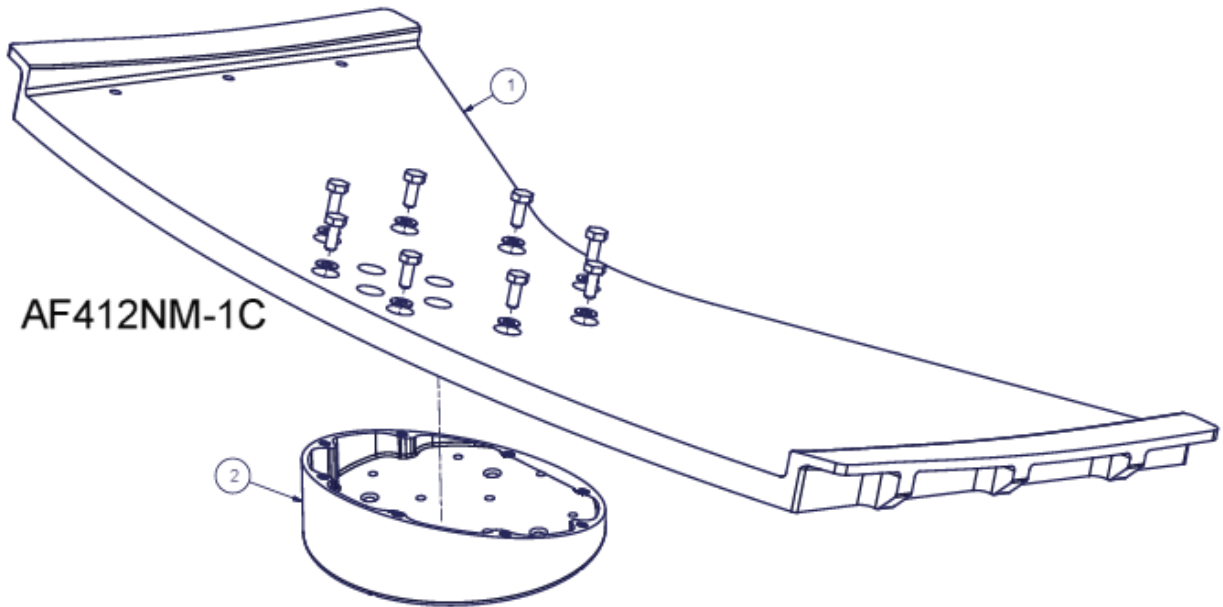
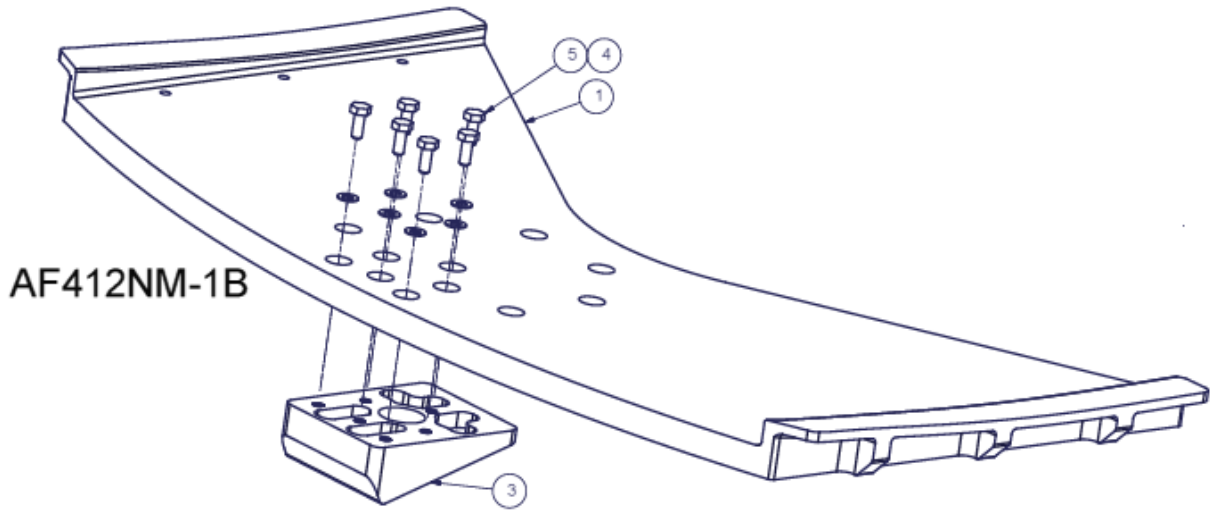

**AIRFILM CAMERA SYSTEMS
MAINTENANCE INSTRUCTIONS
DOCUMENT No. AF412NM-008**

3.1 SCHEDULED INSPECTIONS

The scheduled inspections required by this document are contained on the following checklists. This checklist, when completed, is to become a permanent part of the AF412NM-1 Nose Utility Mount records.

NOTE: There are no field repairs or overhaul allowed for the AF412NM-1 NOSE UTILITY Mount.

If any component fails the following inspections, the mount is to be removed from the helicopter and returned to Airfilm Camera Systems.

3.1.1 100 HOUR INSPECTION INTERVALS

The 100 hour time in service inspections consist of visually inspecting the critical area of the AF412NM-1 Nose Utility Mount.

Due to the simplicity of the mount structure, all scheduled 100 hour inspections consist of the same items since the mount is inspected while installed on the helicopter.

The inspections per Table 3.1.1 are required while the AF412NM-1 Nose Utility Mount is installed on the helicopter at the time in service interval as specified. The inspection is to be performed by maintenance personnel.

TABLE 3.1.1 100 HOUR TIME IN SERVICE INSPECTIONS ON HELICOPTER

Inspect. Interval Hours	Inspection	Maintenance Personnel Initial
100	Visually inspect components for cracks, nicks, dents or scratches	
	Visually inspect hardware for security and tightness	
	Visually inspect components for corrosion	
	Check hardware for correct torques	

3.2 1000 HOUR TIME IN SERVICE INSPECTION INTERVAL

Removed appliance from the helicopter per Section 4.0.

TABLE 3.2.1 COMPONENT INSPECTIONS

Inspect. Interval Hours	Inspection	Maintenance Personnel Initial
1000	Visually inspect bolt holes for damage	
	Visually inspect components for corrosion	
	Visually inspect components for cracks, nicks, dents or scratches	

**AIRFILM CAMERA SYSTEMS
MAINTENANCE INSTRUCTIONS
DOCUMENT No. AF412NM-008**

3.3 SPECIAL INSPECTIONS

Hard Landing: Inspect for evidence of ground contact or damage.
 Remove if indications exist.

3.4 INSPECTION LIMITS

The AF412NM-1 Nose Utility Mount is to be removed from service and returned to Airfilm Camera Systems if the following inspection limits are exceeded.

Cracks:	Any indication
Bolt hole elongation	Any Indication
Corrosion:	Any Indication
Dents, scratches, wear or nicks	Greater than 0.015 inches

4.0 REMOVAL, DISASSEMBLY, REASSEMBLY AND INSTALLATION

4.1 INSTALLATION

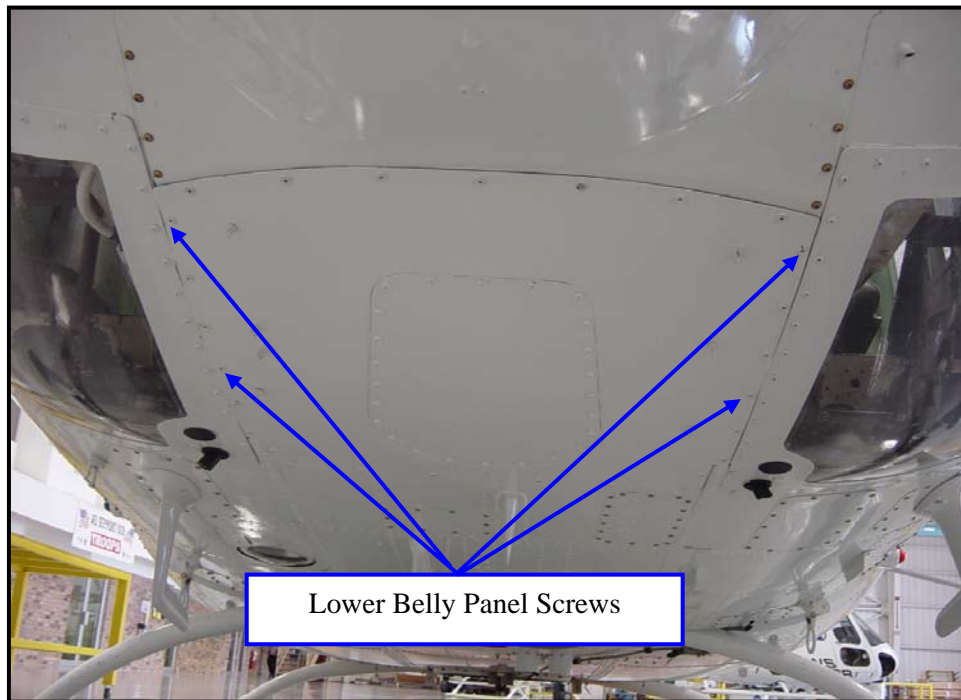

Figure 4.1.1 Lower Belly Cover looking aft

- 4.1.1 Remove quantity 8 existing screws (4 each on left and right sides) between the arrows on the lower belly cover as shown in Figure 4.1.1

**AIRFILM CAMERA SYSTEMS
MAINTENANCE INSTRUCTIONS
DOCUMENT No. AF412NM-008**

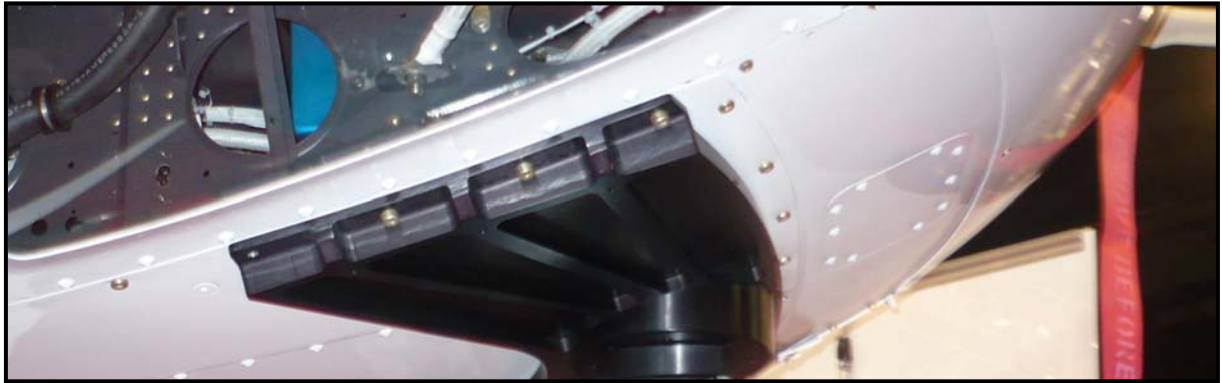

Figure 4.1.2 Mount Installation looking at right side

- 4.1.2 Install AF412NM-1 Nose Mount using quantity 8, AN4-10 Bolts and AN960-416 washers (4 places typical on each side of mount) per Figure 4.1.2.
- Torque nut to 70-80 in-lbs.
 - Mark torqued hardware with torque seal.

4.1.3 Installation Complete

4.2 REMOVAL

4.2.1 Remove quantity 8, AN4-10 Bolts and AN960-416 washers (4 places typical on each side of mount) per Figure 4.1.2.

4.2.2 Remove Mount.

4.2.3 Re-install belly panel with AN4 fasteners, 8 places and original fasteners all other locations

4.2.4 Removal complete.

5.0 WEIGHT AND BALANCE

Table 5.1: COMPONENT WEIGHTS

PART NO.	DESCRIPTION	WEIGHT	STATION)	BL
AF412NM-5	Base Plate Bracket Assembly	13 lbs 5.9 kg	2.5 in 63.5 mm	0 in 0 mm
AF412NM-10	15 Degree Angle Bracket Large	2 lbs .90 kg	2.5 in 63.5 mm	0 in 0 mm
AF412NM-20	15 Degree Angle Bracket Small	1 lbs .45 kg	2.5 in 63.5 mm	0 in 0 mm