

ITEM NO.	QTY.	PART NUMBER	DESCRIPTION
1	1	AFM-ADP-MX15i-10 (NOT SHOWN)	PLATE ADAPTER (THRU HOLES)
2	1	AFM-ADP-MX15i-10-0 (NOT SHOWN)	PLATE ADAPTER (CB HOLES)
3	2	AFH2-1	CARRY HANDLE ASSEMBLY
4	1	MX-15i SENSOR - SHOWN FOR DETAIL	SENSOR PAYLOAD AS REQUIRED
5	6	NAS1351C4-16	SHCS (ALTERNATE P/N MS16998-45 OR MS20004H14) ①

REVISIONS		
REV.	DESCRIPTION	DATE
N/C	INITIAL RELEASE	1/10/2018

NOTE: ABOVE CHART FOR REFERENCE ONLY - USE DWG AFM-ADP-MX15i-1 FOR BOM

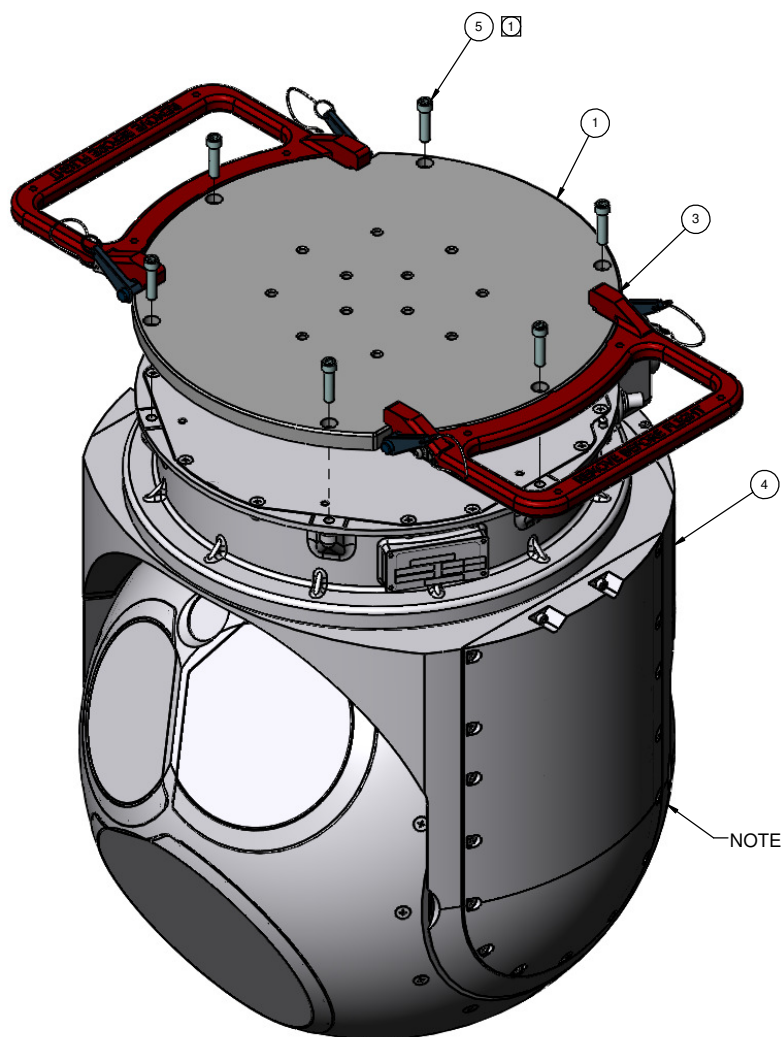

EXPLODED PARTS VIEW

NOTE: WESCAM MX15i SENSOR SHOWN FOR DETAIL, NOT PROVIDED

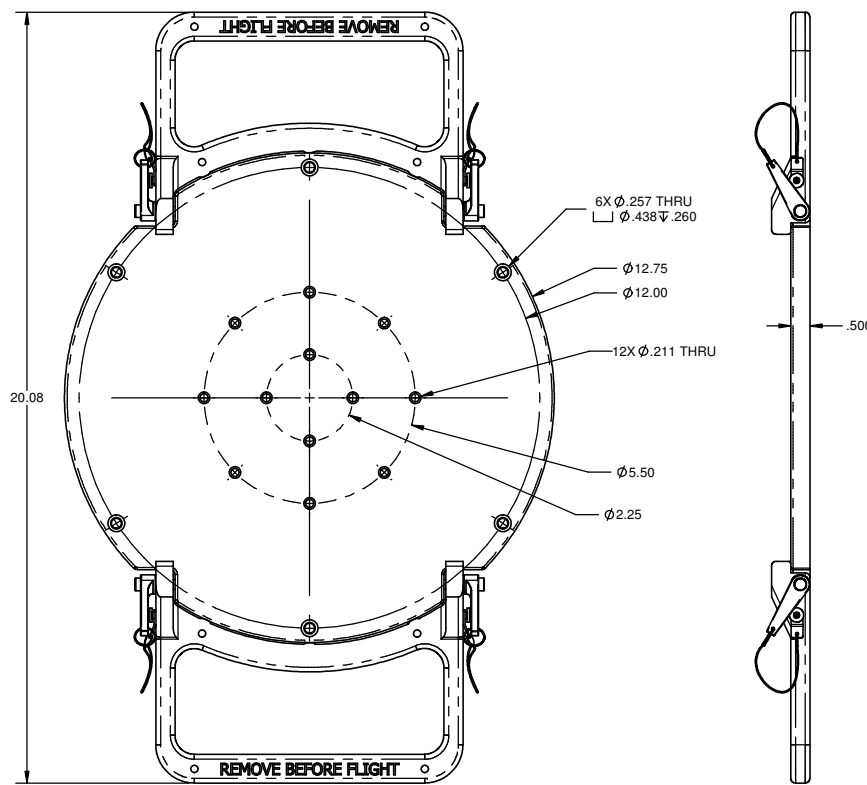

GENERAL DIMENSIONS

**ORDER INFORMATION:**

- AFM-ADP-MX15i-1 ADAPTER ASSY (THRU HOLES)
- AFM-ADP-MX15i-0 ADAPTER ASSY (CB HOLES)
- AFM-ADP-MX15i-A1 ADAPTER ASSY (THRU HOLES - W/O CARRY HANDLES)
- AFM-ADP-MX15i-0A ADAPTER ASSY (CB HOLES - W/O CARRY HANDLES)

NOTES:

- ① ITEM 6 FOR REFERENCE ONLY - NOT PROVIDED ATTACHMENT HARDWARE. ATTACHMENT HARDWARE IS TO BE DETERMINED BY INSTALLER.

UNLESS OTHERWISE NOTED ALL DIMENSIONS ARE IN INCHES

TOLERANCES:

- .X ± .1
- .XX ± .03
- .XXX ± .010
- ANGULAR: ± .5°

BREAK ALL SHARP EDGES .015 MAX

**DRAWING**

	NAME	DATE
DRAWN	C. BROUCEK	01/09/2018
CHECKED	C. MEEKER	01/XX/2018
APPROVED	J. MUELLER	01/XX/2018

**PROPRIETARY NOTICE**

THIS DRAWING AND SPECIFICATION IS THE PROPERTY OF AIRFILM CAMERA SYSTEMS, INC AND SHALL NOT BE COPIED OR DIVULGED IN WHOLE OR IN PART AS THE BASIS FOR MANUFACTURING OR SALE OF THE ITEM OR ITEMS DISCLOSED.

**Airfilm Camera Systems**  
www.airfilm.com Georgetown CA



TITLE: ADAPTER ASSY, MAF STD PATTERN TO MX15i SENSOR

SIZE	DWG. NO.	REV
C	AFM-ADP-MX15i_1	N/C

**STRUCTURAL LIMITATIONS:**

**MAX WEIGHT = 130 LBS**

**LIMIT LOAD FACTOR (Nz) = 3.8**

**MAX DRAG MOMENT (MY) = 9553.77 IN-LBS**

**AFM-ADP-MX15i-1 WEIGHT (W/O GRAB HANDLES) = 3.5 LBS**

INSTALLATION OF THE AFM-ADP-MX15i ADAPTER ONTO THE MX-15i SENSOR.  
QTY 6 NAS1351-4-XX OR MS20004-XX (OR EQVL BOLTS)  
REF TO SHEET 1 FOR COUNTER BORE DEPTH TO DETERMINE THREAD LENGTH REQUIRED

INSTALLATION OF THE AFM-ADP-MX15i ADAPTER ONTO AIRCRAFT/ATTACHMENT  
MOUNT OR QUICK DISCONNECT DEVICE (QDD-1, QDD-1-V2, OR DOVETAIL)  
QTY 4 (DOVETAIL) OR QTY 8 (QDD) AN4-XXA, NAS1351-4-XX, MS20004-XX, OR EQVL

REMOVE AFH2-1 FROM AFM-ADP-MX15i-10 (OR -10-0) PLATE ADAPTER  
BEFORE FLIGHT BY REMOVING THE INSTALLATION PINS FROM EACH  
END OF THE HANDLE (QTY 2X PER HANDLE, 4X TOTAL).

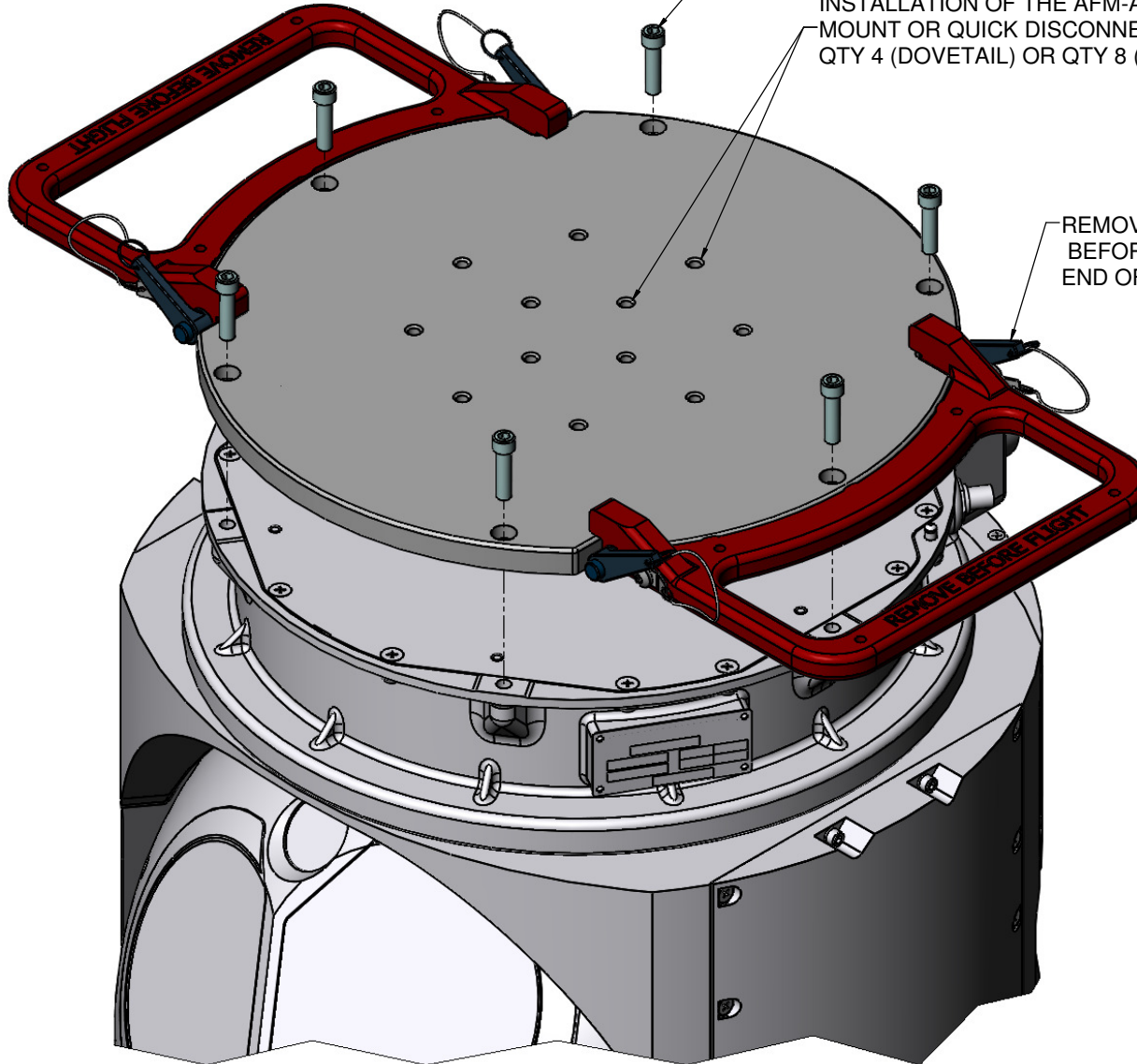

**Airfilm Camera Systems**  
www.airfilm.com Georgetown CA



TITLE: ADAPTER ASSY, MAF STD  
PATTERN TO MX15i SENSOR

SIZE	DWG. NO.	REV
C	AFM-ADP-MX15i_1	N/C

SCALE NA	DO NOT SCALE DRAWING	SHEET 2 OF 2
----------	----------------------	--------------