

**DOCUMENT AFM-AM429-008  
INSTRUCTIONS FOR CONTINUED AIRWORTHINESS  
AFM-AM429-1 AFT UTILITY MOUNT  
FOR THE  
BELL MODEL 429 SERIES  
ROTORCRAFT**

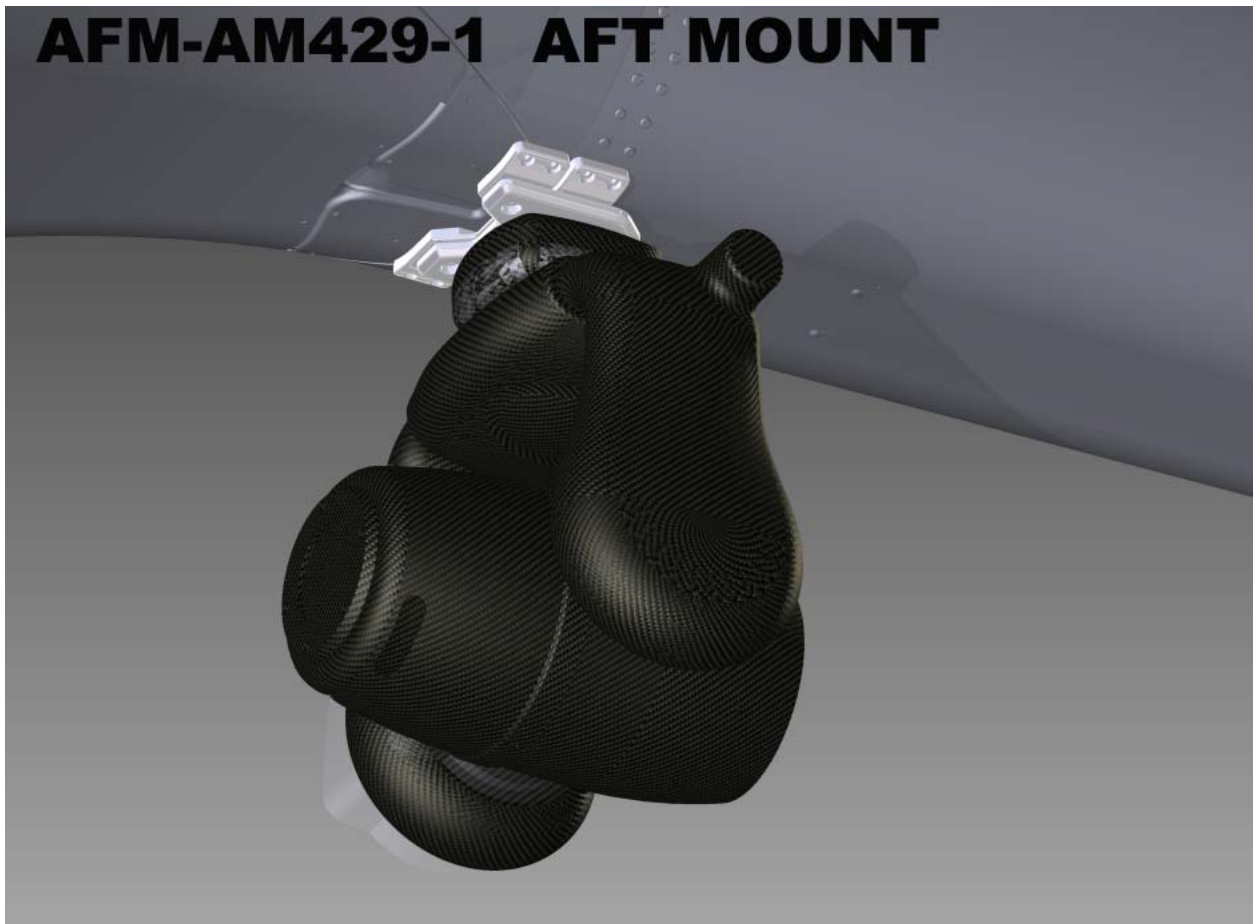

**AIRFILM CAMERA SYSTEMS  
6245 AERODROME WAY  
HANGAR NO. 2  
GEORGETOWN, CA**

**AIRFILM CAMERA SYSTEMS  
MAINTENANCE INSTRUCTIONS  
DOCUMENT No. AFM-AM429-1 AFT UTILITY MOUNT**

**RECORD OF REVISIONS**

| <b>No.</b> | <b>Date</b> | <b>By</b> | <b>DESCRIPTION</b> |
|------------|-------------|-----------|--------------------|
| N/C        | 08/01/11    | AvSpec    | Initial Release    |
|            |             |           |                    |

**LIST OF EFFECTIVE PAGES**

| <b>PAGE NO.</b> | <b>REVISION</b> | <b>DATE</b> |
|-----------------|-----------------|-------------|
| 1               | N/C             | 08/01/11    |
| 2               | N/C             | 08/01/11    |
| 3               | N/C             | 08/01/11    |
| 4               | N/C             | 08/01/11    |
| 5               | N/C             | 08/01/11    |
| 6               | N/C             | 08/01/11    |
| 7               | N/C             | 08/01/11    |
| 8               | N/C             | 08/01/11    |

**AIRFILM CAMERA SYSTEMS  
 MAINTENANCE INSTRUCTIONS  
 DOCUMENT No. AFM-AM429-1 AFT UTILITY MOUNT**

**TABLE OF CONTENTS**

| <b>SECTION</b> | <b>TITLE</b>   | <b>PAGE</b> |
|----------------|--|-------------|
|                | RECORD OF REVISIONS .....  | 2           |
|                | LIST OF EFFECTIVE PAGES.....   | 2           |
|                | TABLE OF CONTENTS .....  | 3           |
| 1.0            | GENERAL.....   | 4           |
| 1.1            | INTRODUCTION .....   | 4           |
| 1.2            | PURPOSE.....   | 4           |
| 1.3            | SCOPE.....   | 4           |
| 1.4            | APPLICABILITY.....   | 4           |
| 1.5            | DOCUMENT CHANGE CONTROL .....  | 4           |
| 1.6            | SPECIAL TOOLS .....  | 4           |
| 2.0            | AIRWORTHINESS LIMITATIONS .....                                      | 4           |
| 3.0            | INSPECTION REQUIREMENTS .....  | 5           |
| 3.1            | SCHEDULED INSPECTIONS .....  | 6           |
| 3.1.1          | 100 HOUR INSPECTION INTERVALS.....                                   | 6           |
|                | TABLE 3.1.1 100 HOUR TIME IN SERVICE INSPECTIONS ON HELICOPTER ..... | 6           |
| 3.1.2          | 500 HOUR INSPECTION INTERVAL.....                                    | 6           |
|                | TABLE 3.1.2 COMPONENT INSPECTIONS.....                               | 6           |
| 3.3            | SPECIAL INSPECTIONS .....  | 7           |
| 3.4            | INSPECTION LIMITS .....  | 7           |
| 4.0            | REMOVAL, DISASSEMBLY, REASSEMBLY AND INSTALLATION.....               | 7           |
| 5.0            | WEIGHT AND BALANCE .....   | 7           |
|                | TABLE 5.1 COMPONENT WEIGHTS.....                                     | 7           |
|                | FIGURE 5.1 EXPLODED VIEW.....  | 8           |

**AIRFILM CAMERA SYSTEMS  
MAINTENANCE INSTRUCTIONS  
DOCUMENT No. AFM-AM429-1 AFT UTILITY MOUNT**

**1.0 GENERAL**

**1.1 INTRODUCTION**

This manual presents the Maintenance Instructions for the installation of the Airfilm Camera Systems Model AFM-AM429-1 Aft Utility Mount for the Bell 429 series rotorcraft. The mount is designed to facilitate the attachment of equipment such as video camera, searchlights and infrared sensors. The cover page of this document shows the typical mount installation.

**1.2 PURPOSE**

The purpose of this document is to provide Maintenance Instructions to inspect the Airfilm Camera Systems Model AFM-AM429-1 Aft Utility Mount.

**1.3 SCOPE**

The scope of this document is limited to information, procedures, requirements and limitations for this Supplemental Type Certificate. When a requirement specified in the appendix to the regulations is not applicable to this Supplemental Type Certificate the requirement will not be included in the Maintenance Instructions.

**1.4 APPLICABILITY**

These Maintenance Instructions are applicable to the Airfilm Camera Systems AFM-AM429-1 Aft Utility Mount.

**1.5 DOCUMENT CHANGE CONTROL**

Changes to this document will be distributed to registered owners of the within AFM-AM429-1 Aft Utility Mount 10 days after the revision is approved. Changes to this document will be indicated by a revision number in the footer, vertical lines adjacent to the change, and in the Record of Revisions.

**1.6 SPECIAL TOOLS**

No special tools are required for maintenance of this appliance.

**2.0 AIRWORTHINESS LIMITATIONS**

NO LIFE LIMITED COMPONENTS ARE AFFECTED

The Airworthiness Limitations section is FAA Approved and specifies inspections and other maintenance required under §§43.16 and 91.403 of the Federal Aviation Regulations unless an alternative program has been FAA Approved.

**AIRFILM CAMERA SYSTEMS  
MAINTENANCE INSTRUCTIONS  
DOCUMENT No. AFM-AM429-1 AFT UTILITY MOUNT**

**3.0 INSPECTION REQUIREMENTS**



**FIGURE 3.1 AFM-AM429-1 Aft Utility Mount**

|   |
|---|
| <b>AIRFILM CAMERA SYSTEMS<br/>         MAINTENANCE INSTRUCTIONS<br/>         DOCUMENT No. AFM-AM429-1 AFT UTILITY MOUNT</b> |
|---|

**3.1 SCHEDULED INSPECTIONS**

The scheduled inspections required by this document are contained on the following checklists. This checklist, when completed, is to become a permanent part of the AFM-AM429-1 Aft Utility Mount records.

**NOTE: There are no field repairs or overhaul allowed for the AFM-AM429-1 Aft Utility Mount.**

If any component fails the following inspections, the mount is to be removed from the helicopter and returned to Airfilm Camera Systems.

**3.1.1 100 HOUR INSPECTION INTERVALS**

The 100 hour time in service inspections consist of visually inspecting the critical area of the AFM-AM429-1 Aft Utility Mount.

Due to the simplicity of the mount structure, all scheduled 100 hour inspections consist of the same items since the mount is inspected while installed on the helicopter.

The inspections per Table 3.1.1 are required while the AFM-AM429-1 Aft Utility Mount is installed on the helicopter at the time in service interval as specified. The inspection is to be performed by maintenance personnel.

**TABLE 3.1.1 100 HOUR TIME IN SERVICE INSPECTIONS ON HELICOPTER**

| Inspect.<br>Interval<br>Hours | Inspection  | Maintenance<br>Personnel<br>Initial |
|-------------------------------|---|-------------------------------------|
| 100                           | Visually inspect components for cracks, nicks, dents or scratches |                                     |
| 100                           | Visually inspect hardware for security and tightness              |                                     |
| 100                           | Visually inspect components for corrosion                         |                                     |
| 100                           | Check hardware for correct torques                                |                                     |

**3.1.2 500 HOUR INSPECTION INTERVALS**

Remove appliance from helicopter in accordance with Section 4.0.

**TABLE 3.1.2 COMPONENT INSPECTIONS**

| Inspect.<br>Interval<br>Hours | Inspection  | Maintenance<br>Personnel<br>Initial |
|-------------------------------|---|-------------------------------------|
| 500                           | Visually inspect bolt holes for damage                            |                                     |
| 500                           | Visually inspect components for corrosion                         |                                     |
| 500                           | Visually inspect components for cracks, nicks, dents or scratches |                                     |

|   |
|---|
| <b>AIRFILM CAMERA SYSTEMS<br/>         MAINTENANCE INSTRUCTIONS<br/>         DOCUMENT No. AFM-AM429-1 AFT UTILITY MOUNT</b> |
|---|

**3.3 SPECIAL INSPECTIONS**

Hard Landing:      Inspect for evidence of ground contact or damage.  
                              Remove if indications exist.

**3.4 INSPECTION LIMITS**

The AFM-AM429-1 Aft Utility Mount is to be removed from service and returned to Airfilm Camera Systems if the following inspection limits are exceeded.

|                                 |                           |
|---------------------------------|---------------------------|
| Cracks:                         | Any indication            |
| Bolt hole elongation            | Any Indication            |
| Corrosion:                      | Any Indication            |
| Dents, scratches, wear or nicks | Greater than 0.015 inches |

**4.0 REMOVAL, DISASSEMBLY, REASSEMBLY AND INSTALLATION**

After initial installation, the AFM-AM429-10, AFM-AM429-11, AFM-AM429-12, AFM-AM429-15, AFM-AM429-16, and AFM-AM429-17 (Ref. Figure 5.1 below) are not removable. The AFM-AM429-14 Tie Plate may be removed by removal of the 6 ea. NAS1351-4-10R (or AN4-15A) bolts and MS35338-44 Lock Washers.

Reinstallation of the AFM-AM429-14 Tie Plate is by reinstallation of the 6 ea. NAS1351-4-10R (or AN4-15A) bolts and new MS35338-44 Lock Washers. Torque to 50 - 70 in-lb.

**5.0 WEIGHT AND BALANCE**

**Table 5.1: COMPONENT WEIGHTS**

| PART NO.    | DESCRIPTION       | WEIGHT | STATION)                | BL               |
|-------------|-------------------|--------|-------------------------|------------------|
| AFM-NM429-1 | AFT UTILITY MOUNT | 4.0    | 363.00 in<br>9220.20 mm | 0.0 in<br>0.0 mm |

**AIRFILM CAMERA SYSTEMS  
MAINTENANCE INSTRUCTIONS  
DOCUMENT No. AFM-AM429-1 AFT UTILITY MOUNT**

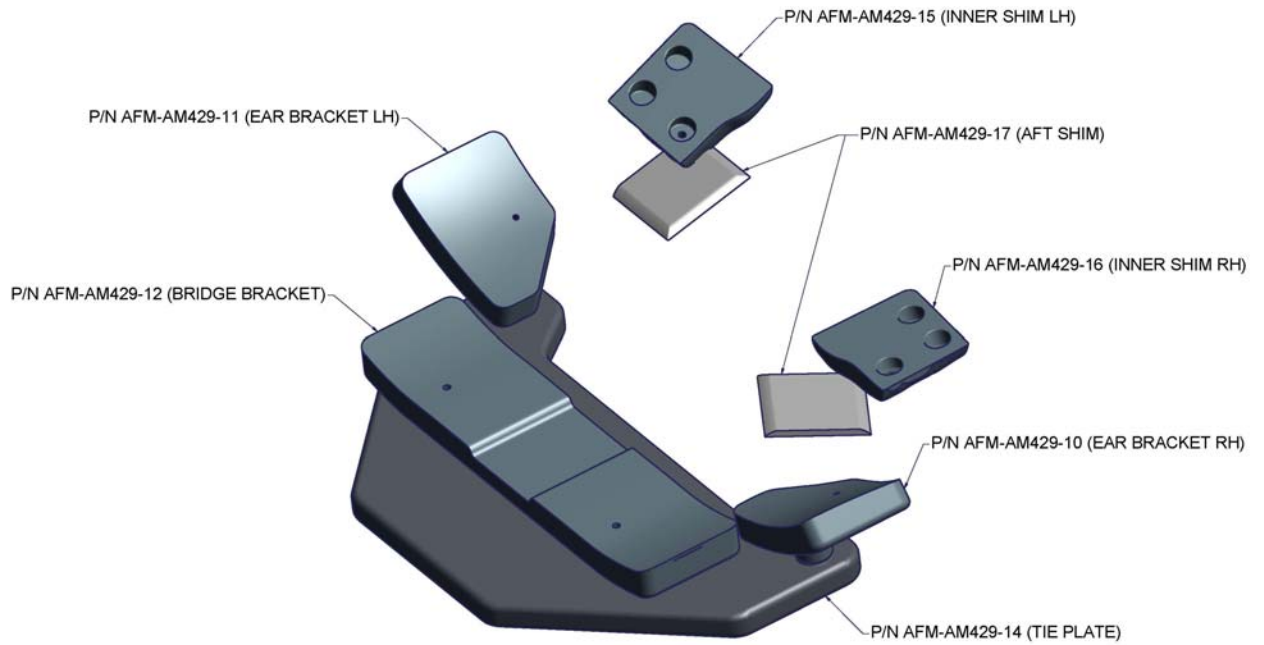

**FIGURE 5.1 EXPLODED VIEW**