

AIRFILM  
CAMERA SYSTEMS  
REPORT AFM-BH-INST-IMT  
INSTALLATION INSTRUCTIONS  
UTILITY MOUNT ASSY, I-MOUNT,  
UH-60 BLACKHAWK

**DATE ISSUED: 04/23/2019**

Airfilm Camera Systems  
6245 Aerodrome Way, Hangar No. 2  
PO Box 1352  
Georgetown, CA 95634

**LOG OF REVISIONS**

REVISION	DATE	PAGES EFFECTED	COMMENTS
N/C	04/23/2019	ALL	Original Issue
A	05/09/2019	ALL	Revised installation hardware from AN4 to AN3 sized bolts, removed instructions for nutplate installation.
B	11/11/2019	ALL	Revised step 5 in Section 3.1 that calls out alternate installation hardware for AF-BH-IMT-1 when mounted on S-70i helicopter.

AIRFILM CAMERA SYSTEMS INC PROPRIETARY RIGHTS ARE INCLUDED IN THE INFORMATION DISCLOSED HEREIN.  
NEITHER THESE DOCUMENTS NOR THE INFORMATION DISCLOSED HEREIN SHALL BE REPRODUCED, USED, OR  
DISCLOSED IN WHOLE OR IN PART WITHOUT THE WRITTEN PERMISSION OF AIRFILM CAMERA SYSTEMS INC.

## 1.0 INTRODUCTION

Airfilm Camera Systems provides a variety of utility mounts designed specifically for the Sikorsky Aircraft UH-60A/L/M and S-70 (Blackhawk) helicopter.

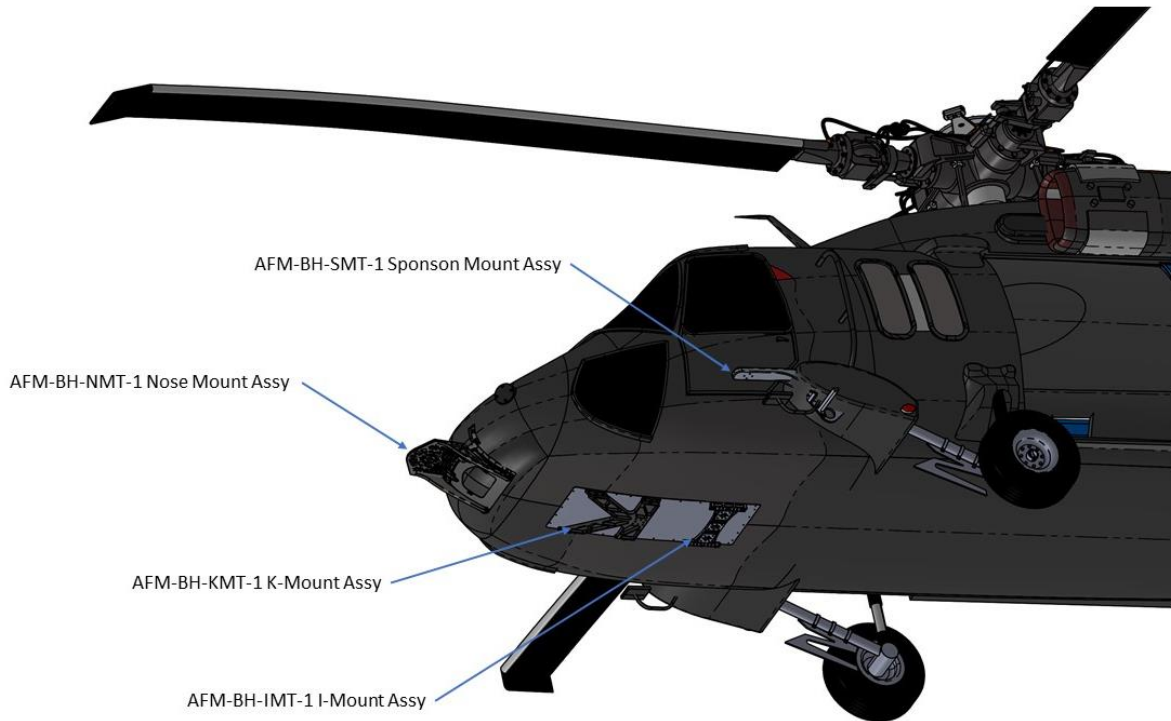

Figure 1. Airfilm Camera System Utility Mount Assemblies on UH-60 (CAD Illustration)

- AFM-BH-NMT – Nose Mount Assembly
- AFM-BH-KMT – K-Mount Assembly
- AFM-BH-IMT – I-Mount Assembly
- AFM-BH-SMT – Sponson Mount Assembly

This document provides the detailed installation instructions for the AFM-BH-IMT I-Mount assembly. Installation instructions for the other mounts noted are in separate documents.

**2.0 AFM-BH-IMT-1 I-MOUNT ASSEMBLY DESCRIPTION**

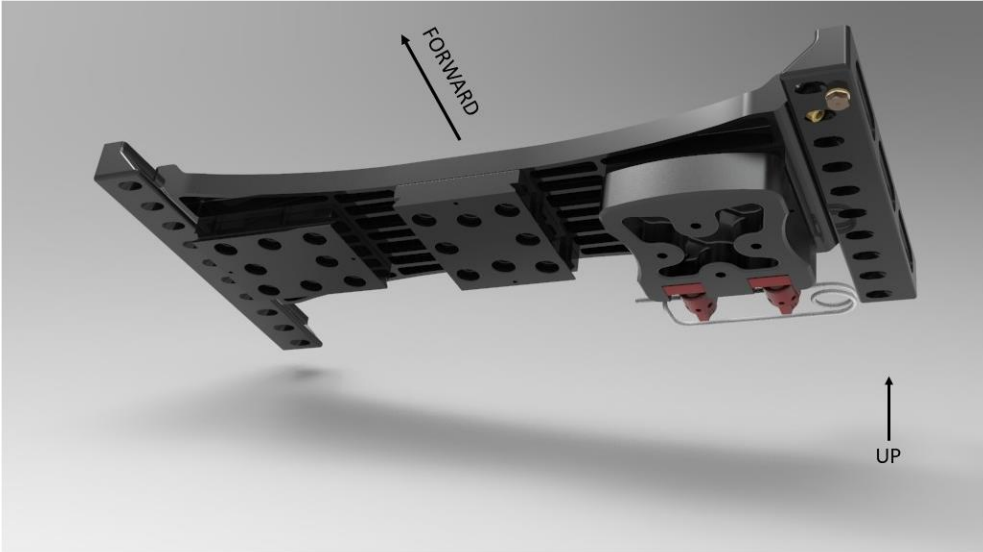

Figure 2. AF-BH-IMT-1 Utility Mount Assembly with Optional DT-1 Quick Release Accessories (CAD Illustration)

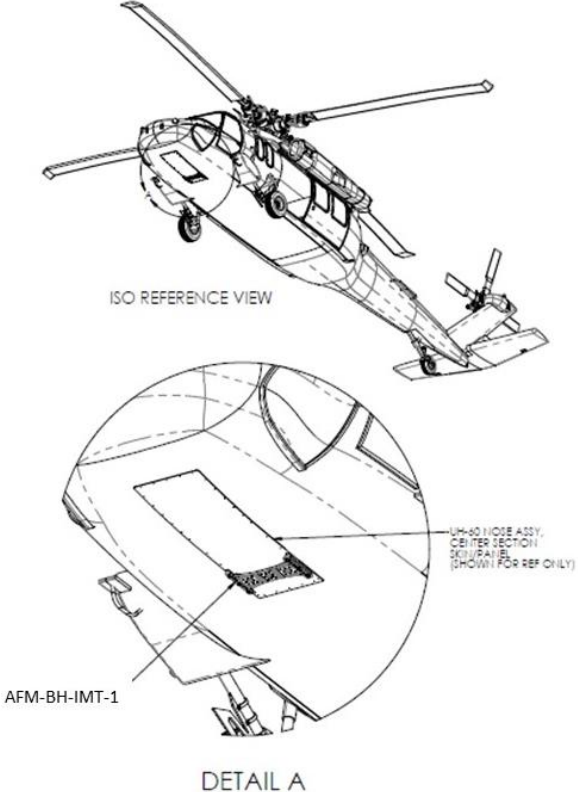

Figure 3. CAD Illustration View Showing AF-BH-IMT-1 Installation on a UH-60 Helicopter

AIRFILM CAMERA SYSTEMS INC PROPRIETARY RIGHTS ARE INCLUDED IN THE INFORMATION DISCLOSED HEREIN. NEITHER THESE DOCUMENTS NOR THE INFORMATION DISCLOSED HEREIN SHALL BE REPRODUCED, USED, OR DISCLOSED IN WHOLE OR IN PART WITHOUT THE WRITTEN PERMISSION OF AIRFILM CAMERA SYSTEMS INC.

<b>Airfilm Camera Systems</b> <b>UTILITY MOUNT ASSY, I-MOUNT, UH-60 BLACKHAWK,</b> <b>INSTALLATION INSTRUCTIONS</b>	<b>AFM-BH-INST-IMT</b> <b>Rev. B</b>
---	---

The Airfilm AF-BH-IMT Utility Mount allows for the attachment of utility equipment such as speakers, cameras, and sensor instruments to be mounted on the Sikorsky UH-60A/L/M and S-70 Model Helicopters. Eligible models are:

H-60 Models A, L, M and S-70, S70i

The AF-BH-IMT Utility Mount consists of a machined mounting plate and two side rails that attach to the lower, center skin panel of the nose assembly, using existing fastener holes. The payload is mounted to the Utility Mount assembly with the option to use various quick disconnect or vibration isolating devices.

After installation, calculate weight and balance for installed items and check for proper loading of aircraft. Antenna, lights, and additional installed equipment may need to be relocated to provide clearance for the utility mount system.

**Note 1** – If camera / sensor / speaker installations require additional power or system requirements beyond the placarded OEM auxiliary power outlet, additional certification(s) may be required.

**Note 2** – The AFM-BH-IMT I-Mount can be installed concurrently with the AFM-BH-NMT-1 Nose Mount assembly, the AFM-BH-KMT K-Mount assembly, and/or the AFM-BH-SMT-1, -2, or -3 Sponson Mount assembly.

### 3.0 AF-BH-IMT UTILITY MOUNT INSTALLATION

#### 3.1 Installation of Utility Mount Assembly

Reference Airfilm drawing AFM-BH-INST-005 for detailed views, dimensions, and hardware used for installation.

- 1) Remove the lower center skin panel from the nose assembly of the UH-60.

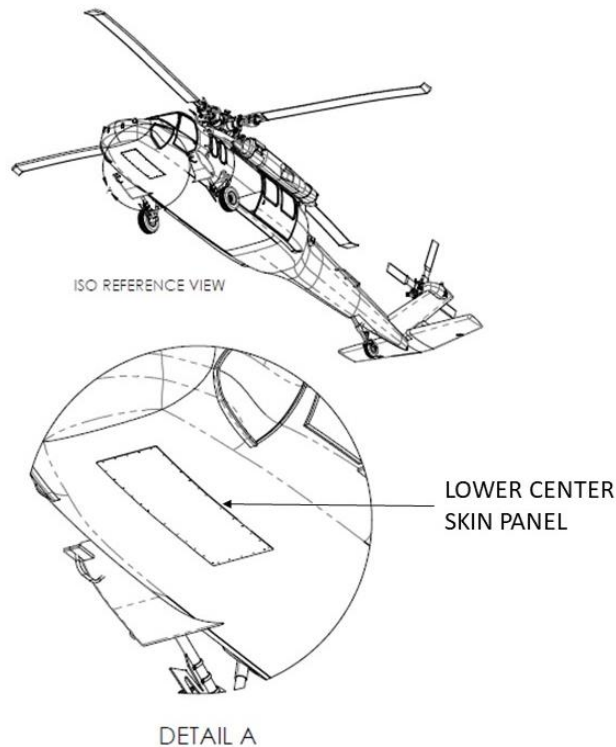

Figure 4. UH-60 Lower Center Skin Panel

2) Assemble the AFM-BH-IMT-1 using quantity (8) NAS1351-4-10 socket head cap screws as shown in the following figure. Torque Fasteners 75-95 in-lbs.

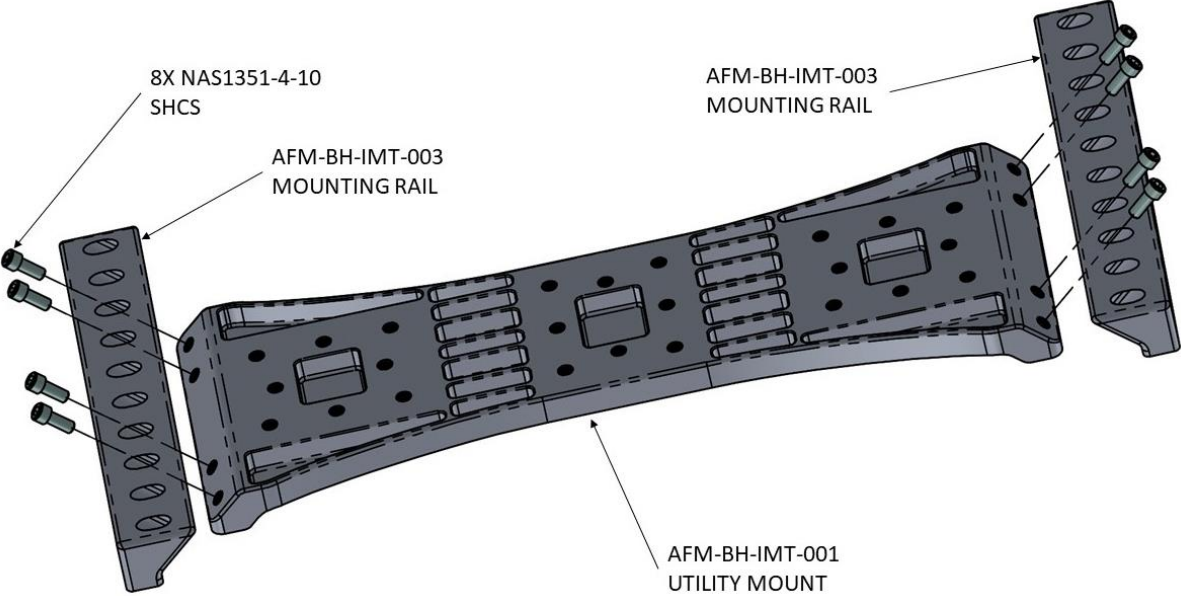

Figure 5. Exploded Assembly View of AFM-BH-IMT-1 I-Mount (CAD Illustration)

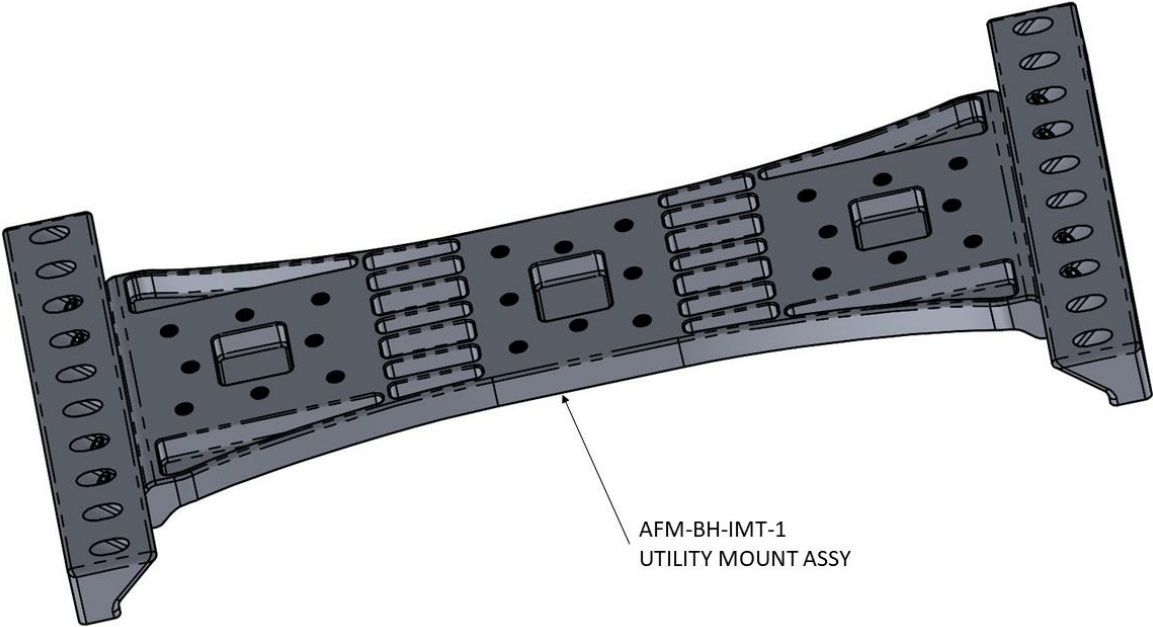

Figure 6. Assembled View of AFM-BH-IMT-1 I-Mount (CAD Illustration)

- 3) Position the AFM-BH-IMT-1 I-Mount assembly on the UH-60 Lower Center Skin Panel as shown on Airfilm Installation Drawing AFM-BH-INST-005. Using the existing holes on the Center Skin Panel, match drill quantity (6) diameter 0.201" holes on the AFM-BH-IMT-1 I-Mount assembly. Maintain a minimum edge distance of 0.50" on all drilled holes (dimension taken from center of hole).
- 4) Reinstall the Lower Center Skin Panel using the existing fasteners. Do not install the (6) fasteners where the AFM-BH-IMT-1 Utility Mount will be installed.
- 5) Install the AFM-BH-IMT-1 using (6) AN3-17A bolts and (6) NAS620-10 washers. (Note: If installing the AFM-BH-IMT-1 I-Mount on the S-70i Helicopter, use (6) AN3-22A bolts in place of the (6) AN3-17A bolts.)
- 6) Torque mount fasteners to 50-70 in-lbs.
- 7) Note: Once installed, the AFM-BH-IMT-001 Utility Mount can be repositioned fore or aft by relocating the (8) NAS1351-4-10 socket head caps screws on the AFM-BH-IMT-003 Mounting Rails. The five different configurations/positions are as follows:

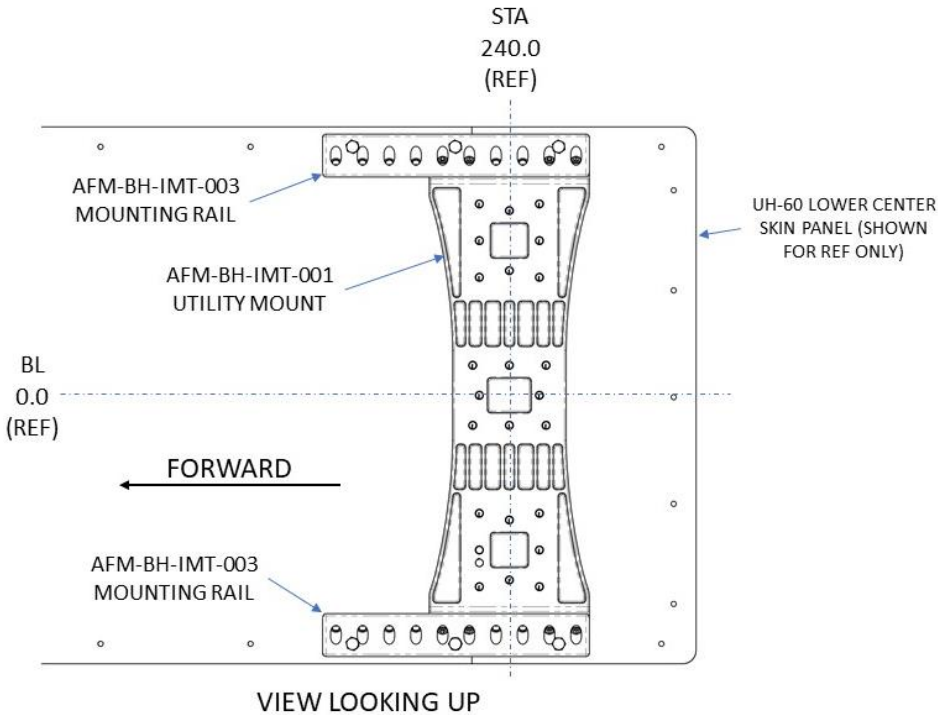

Figure 7. Configuration #1 – AFM-BH-IMT-1 I-Mount, Aft Position

**Airfilm Camera Systems**  
**UTILITY MOUNT ASSY, I-MOUNT, UH-60 BLACKHAWK,**  
**INSTALLATION INSTRUCTIONS**

**AFM-BH-INST-IMT**  
**Rev. B**

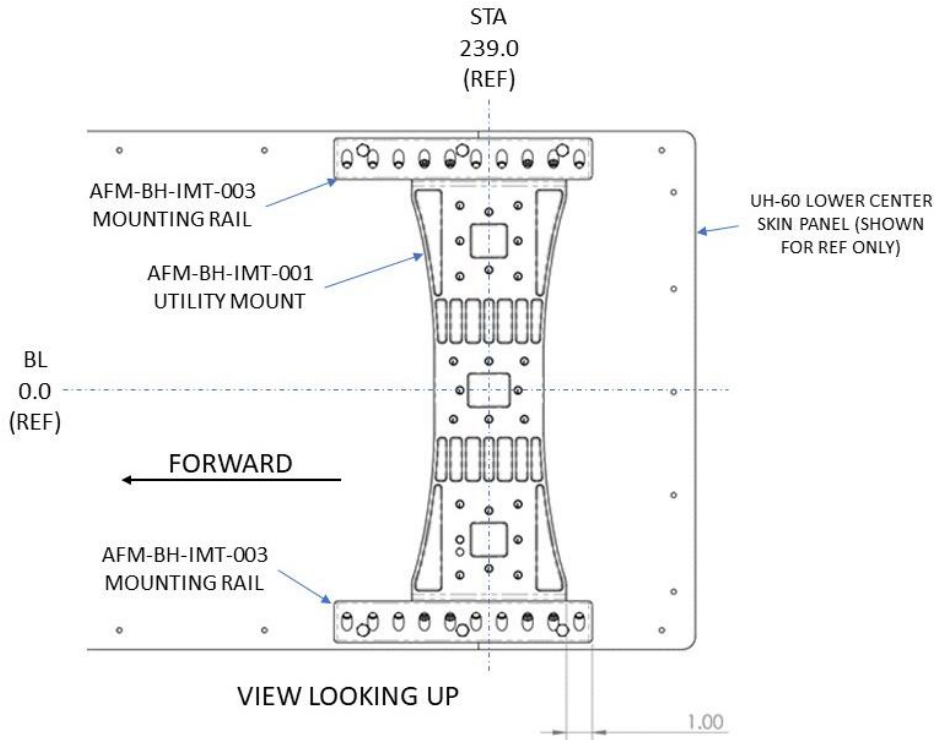

Figure 8. Configuration #2 – AFM-BH-IMT-1 I-Mount, Aft/Center Position

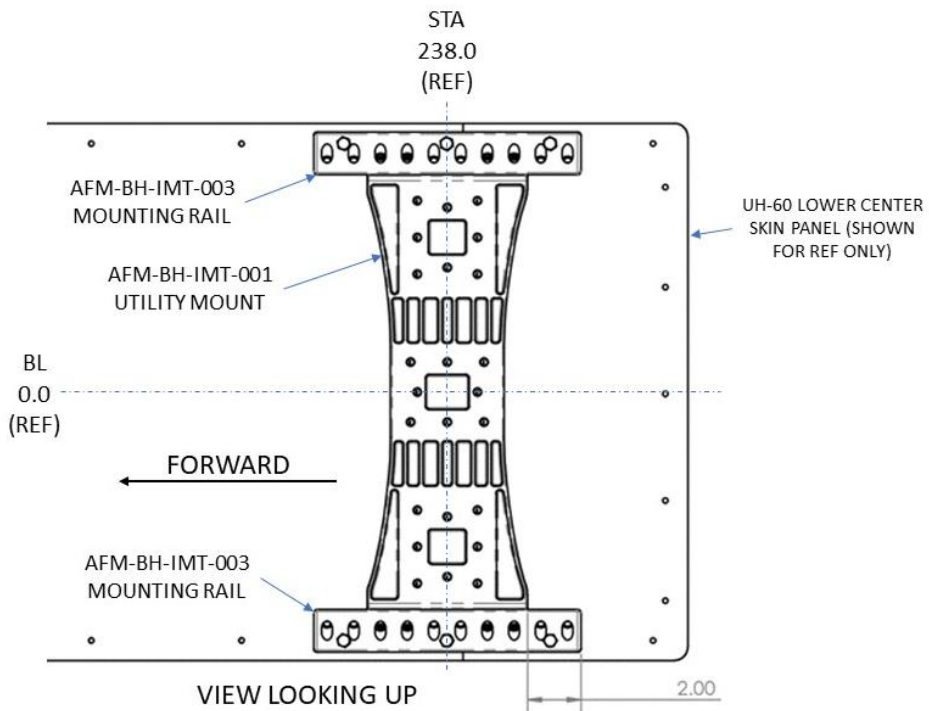

Figure 9. Configuration #3 – AFM-BH-IMT-1 I-Mount, Center Position

AIRFILM CAMERA SYSTEMS INC PROPRIETARY RIGHTS ARE INCLUDED IN THE INFORMATION DISCLOSED HEREIN. NEITHER THESE DOCUMENTS NOR THE INFORMATION DISCLOSED HEREIN SHALL BE REPRODUCED, USED, OR DISCLOSED IN WHOLE OR IN PART WITHOUT THE WRITTEN PERMISSION OF AIRFILM CAMERA SYSTEMS INC.



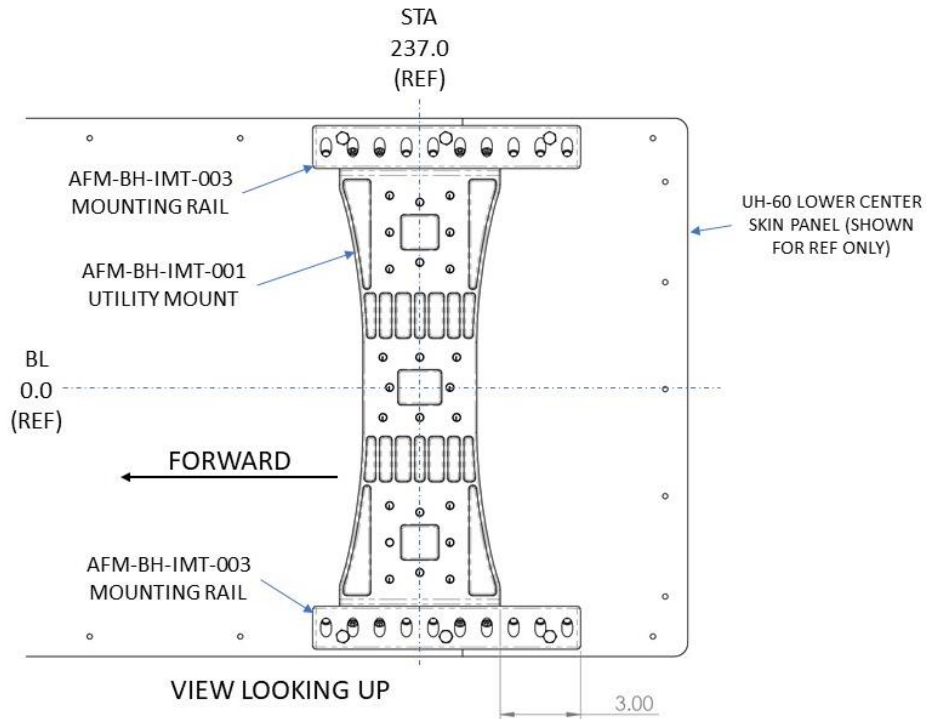

Figure 10. Configuration #4 – AFM-BH-IMT-1 I-Mount, Forward/Center Position

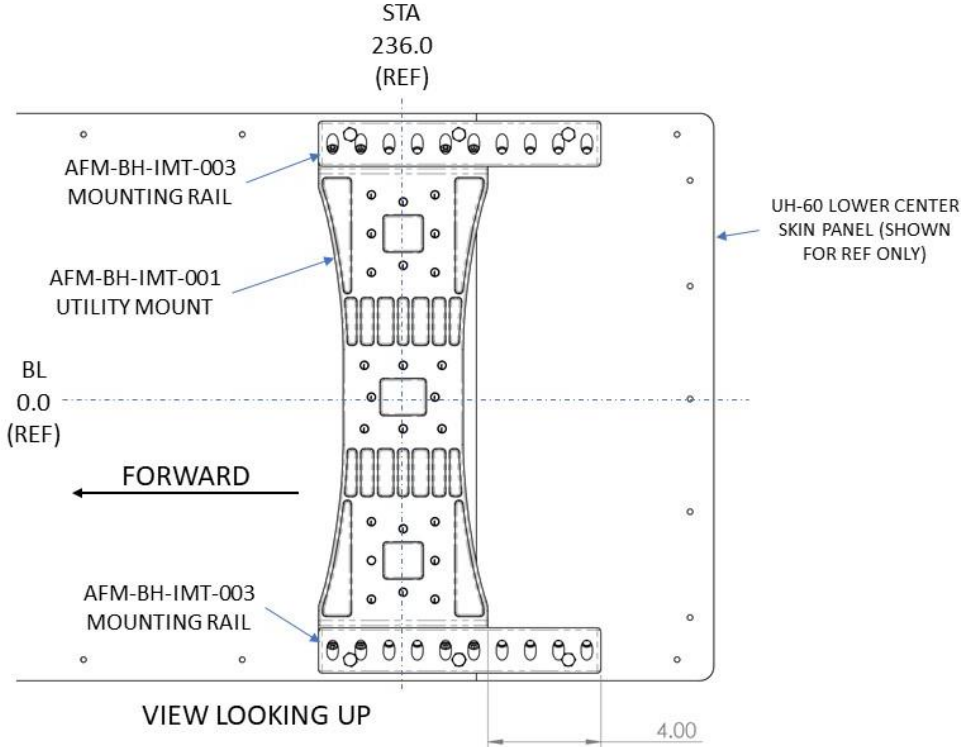

Figure 11. Configuration #5 – AFM-BH-IMT-1 I-Mount, Forward Position

8) The payload(s) can be installed using the optional Airfilm DT-1 and/or the optional Airfilm QDD-1 Quick Disconnect devices at three separate lateral locations on the utility mount as shown below. (Refer to Airfilm Camera Systems drawing numbers DT\_1A and QDD-1\_1 for installation instructions and specifications.)

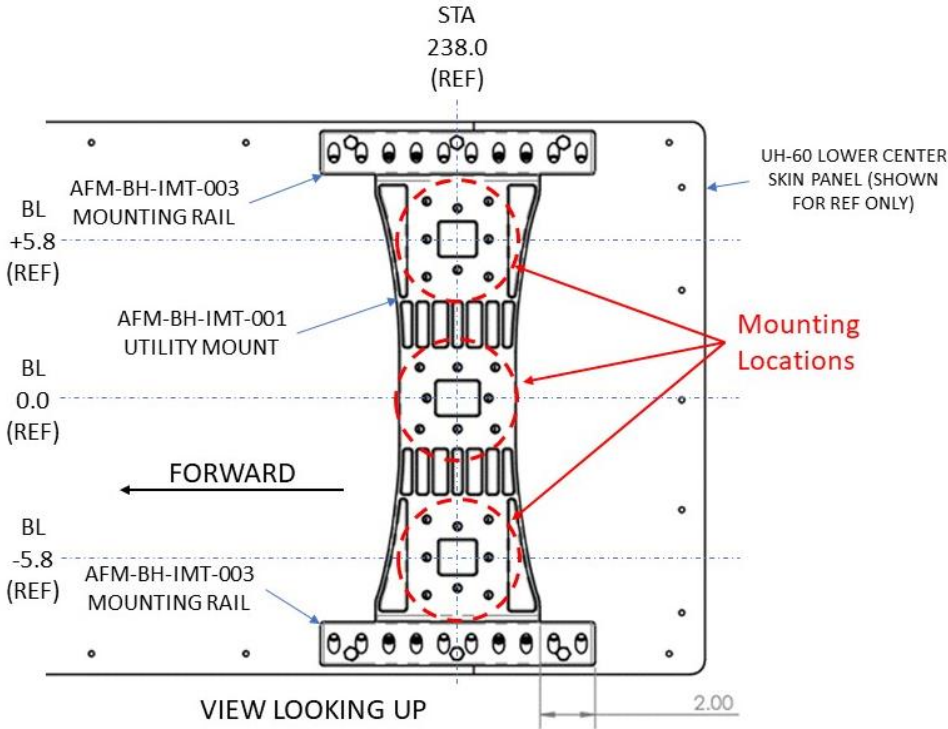

Figure 12. Lateral Mounting Locations – AFM-BH-IMT-1 I-Mount

**NOTES:**

- a) AF-BH-IMT installation weight is 7.0 lbs.
- b) The payload package for the installation is limited to a maximum allowable frontal area of 1.6 ft<sup>2</sup> and a weight of 55 lbs.
- c) When Airfilm payload Disconnect Devices (QDD-1-1 or DT-1-1) are installed, the payload can be removed and installed by crew.
- d) If camera/sensor/searchlight installations require additional power or system requirements beyond the placarded OEM auxiliary power outlet, additional certification(s) may be required.

**3.2 Revise weight and balance per Table 1**

The following table presents a sample calculation for the AF-BH-IMT installation. It also contains the Weight and C.G. information for each of the possible configurations.

Table 1. Weight and Balance Information for AFM-BH-IMT-1 Utility Mount

### SAMPLE CALCULATION

<b>AFM-BH-IMT-1 WEIGHT AND STATIONS</b> <b>FOR CAMERA / SENSOR SYSTEMS</b> <i>UH-60 MODELS</i> <small>SELECT ONE OF THE FOLLOWING CONFIGURATIONS OF AFM-BH-IMT-1 UTILITY MOUNT(SEE INSTALLATION INSTRUCTIONS)</small>	<b>LONGITUDINAL ARM</b>		<b>LATERAL ARM</b> <small>Use Positive (+) for LH Install Use Negative (-) for RH Install</small>						
			LEFT HAND STATION		CENTER STATION		RIGHT HAND STATION		
			WEIGHT (LBS)	ARM (INCHES)	WEIGHT (LBS)	ARM (INCHES)	WEIGHT (LBS)	ARM (INCHES)	WEIGHT (LBS)
EMPTY MOUNT									
AF-BH-IMT	7.00	105.00			0.00				
CONFIGURATION #1 - AFT POSITION (See Installation Instructions)	WEIGHT (LBS)	ARM (INCHES)	WEIGHT (LBS)	ARM (INCHES)	WEIGHT (LBS)	ARM (INCHES)	WEIGHT (LBS)	ARM (INCHES)	ARM (INCHES)
PAYLOAD		103.00		5.80		0.00			-5.80
QUICK DISCONNECT DEVICE (SELECT ONE OF THE FOLLOWING)									
DT-1-1 (2.40 lbs ea)		103.00		5.80		0.00			-5.80
QDD-1 (3.53 lbs ea)		103.00		5.80		0.00			-5.80
CONFIGURATION #2 - AFT/CENTER POSITION (See Installation Instructions)	WEIGHT (LBS)	ARM (INCHES)	WEIGHT (LBS)	ARM (INCHES)	WEIGHT (LBS)	ARM (INCHES)	WEIGHT (LBS)	ARM (INCHES)	ARM (INCHES)
PAYLOAD		104.00		5.80		0.00			-5.80
QUICK DISCONNECT DEVICE (SELECT ONE OF THE FOLLOWING)									
DT-1-1 (2.40 lbs ea)		104.00		5.80		0.00			-5.80
QDD-1 (3.53 lbs ea)		104.00		5.80		0.00			-5.80
CONFIGURATION #3 - CENTER POSITION (See Installation Instructions)	WEIGHT (LBS)	ARM (INCHES)	WEIGHT (LBS)	ARM (INCHES)	WEIGHT (LBS)	ARM (INCHES)	WEIGHT (LBS)	ARM (INCHES)	ARM (INCHES)
PAYLOAD	49.00	105.00	31.00	5.80		0.00	18.00		-5.80
QUICK DISCONNECT DEVICE (SELECT ONE OF THE FOLLOWING)									
DT-1-1 (2.40 lbs ea)	4.80	105.00	2.40	5.80		0.00	2.40		-5.80
QDD-1 (3.53 lbs ea)		105.00		5.80		0.00			-5.80
CONFIGURATION #4 - FORWARD/CENTER POSITION (See Installation Instructions)	WEIGHT (LBS)	ARM (INCHES)	WEIGHT (LBS)	ARM (INCHES)	WEIGHT (LBS)	ARM (INCHES)	WEIGHT (LBS)	ARM (INCHES)	ARM (INCHES)
PAYLOAD		106.00		5.80		0.00			-5.80
QUICK DISCONNECT DEVICE (SELECT ONE OF THE FOLLOWING)									
DT-1-1 (2.40 lbs ea)		106.00		5.80		0.00			-5.80
QDD-1 (3.53 lbs ea)		106.00		5.80		0.00			-5.80
CONFIGURATION #5 - FORWARD POSITION (See Installation Instructions)	WEIGHT (LBS)	ARM (INCHES)	WEIGHT (LBS)	ARM (INCHES)	WEIGHT (LBS)	ARM (INCHES)	WEIGHT (LBS)	ARM (INCHES)	ARM (INCHES)
PAYLOAD		107.00		5.80		0.00			-5.80
QUICK DISCONNECT DEVICE (SELECT ONE OF THE FOLLOWING)									
DT-1-1 (2.40 lbs ea)		107.00		5.80		0.00			-5.80
QDD-1 (3.53 lbs ea)		107.00		5.80		0.00			-5.80

Mount installation Weight 7.00  
 Payload Total Weight 53.80  
**Total Additional Weight = 60.8 lbs**

<b>LONGITUDINAL MOMENT</b> (IN-LBS)
6384.0

<b>LATERAL MOMENT</b> (IN-LBS)
75.4

*Note – Sample Calculation is provided for Configuration #3 with Power Sonix PSAIR22 (dual horn) installed on LH, and a PSAIR12 (single horn) of the RH. Each Payload is installed with a DT-1-1 Dovetail.*

- 1) Install appropriate Placards in full view of pilot.

**Reduce published  $V_{NE}$  by 10 KIAS with a payload  
installed**

- 2) Make appropriate log book entry for installation.
- 3) Return to service.

#### **4.0 Removing the AFM-BH-IMT-1 Utility Mount Assembly**

- 1) Remove entire AFM-BH-IMT-1 Utility Mount Assembly and associated hardware.
- 2) Reinstall original hardware into the UH-60 lower skin panel.
- 3) Calculate weight and balance.
- 4) Make appropriate log book entry.
- 5) Return aircraft to service.

## APPENDIX A – Quick Disconnect Devices

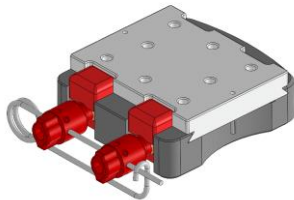

**DT-1-1**  
DOVE TAIL  
(CAD Illustration)

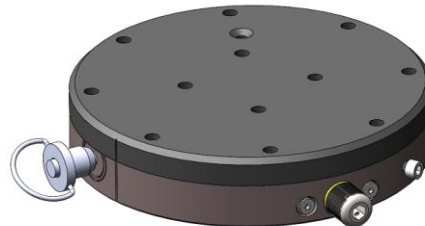

**QDD-1**  
QUICK DISCONNECT  
(CAD Illustration)

## APPENDIX B – METHOD OF ADDING ADDITIONAL SENSOR / CAMERA / PAYLOADS

**Overview**

This Appendix provides the requirements necessary to qualify sensor / camera / speaker payloads – IF NEEDED.

It may also be used as a check list for previously approved sensor /cameras / speaker payloads if desired.

The STC flight testing was conducted and the STC approved with the largest and heaviest payload expected for use with this mount. The specific sensor/cameras/light not listed in the installation manual of equal or lesser than the limit case are accepted with this follow-on test plan.

**Sensor / Camera / Speaker payload**

Make & Model \_\_\_\_\_

**Test Team**

**Pilot(s)**

\_\_\_\_\_  
Print Name

**Mechanic and/or Engineer and/or Camera Operator**

\_\_\_\_\_  
Print Name

**A.1. Test Aircraft Configuration and Location**

**Aircraft Model, Registration & Serial Number**

\_\_\_\_\_ Model                      \_\_\_\_\_ Registration Number                      \_\_\_\_\_ Serial Number

**Test Configurations**

Empty weight with appropriate fuel and camera system installed  
 Takeoff Gross weight with crew

Configuration	Gross Weight	Longitudinal CG	Lateral CG
Empty Wt			
Takeoff Wt			

**Test Location**

\_\_\_\_\_ Airport or Test Site

**Test Conditions**

Date: \_\_\_\_\_

Weather: Ceiling \_\_\_\_\_ Visibility \_\_\_\_\_ Winds \_\_\_\_\_

Altimeter \_\_\_\_\_ Field Elevation \_\_\_\_\_

Flight Time: Engine Start \_\_\_\_\_ Shut Down \_\_\_\_\_ Flt Time \_\_\_\_\_

**A.2. Flight Test**

**A.2.1. Overview**

Applicable regulations demonstrated for compliance are indicated with the following symbol ➔. The testing required for the compliance findings of this installation will be made by as a subject/qualitative evaluation. Although the most critical CG is at the aft limit for most tests this configuration is mounted forward of the mast should not approach the aft limits. This also depends on crew loading. The test team conducts the following tests and evaluations and mark initial the box at the end of each section if the configuration successfully passes the requirements.

**A.2.2. FAR § 29.51 Takeoff**

**A.2.2.1. Applicable Regulation**

➔(a) The takeoff data required by Secs. 29.53, 29.55, 29.59, 29.60, 29.61, 29.62, 29.63, and 29.67 must be determined--

- (1) At each weight, altitude, and temperature selected by the applicant; and
- (2) With the operating engines within approved operating limitations.

➔ (b) Takeoff data must--

- (1) Be determined on a smooth, dry, hard surface; and
- (2) Be corrected to assume a level takeoff surface.
- (c) No takeoff made to determine the data required by this section may require exceptional piloting skill or alertness, or exceptionally favorable conditions.

**A.2.2.2. Method of Compliance**

The recommended takeoff procedure must be demonstrated to remain clear of the HV "avoid" areas without requiring exceptional piloting skill or exceptionally favorable conditions.

A qualitative evaluation of the ability to safely land at any point along the flight path will be made using judgment and experience with the basic aircraft. No engine failure testing at low altitude will be conducted.

The normal takeoff procedures will be used for the sensor/camera/light payload and mount installation.

**A.2.2.3. Findings**

Satisfactory \_\_\_\_\_

**A.2.3. FAR § 29.71 Glide Performance**

**A.2.3.1. Applicable Regulation**

➔For each category B helicopter, except multiengine helicopters meeting the requirements of Sec. 29.67(b) and the powerplant installation requirements of category A, the steady angle of glide must be determined in autorotation--

- (a) At the forward speed for minimum rate of descent as selected by the applicant;
- ➔ (b) At the forward speed for best glide angle;
- (c) At maximum weight; and
- ➔ (d) At the rotor speed or speeds selected by the applicant



**A.2.3.2. Method of Compliance**

(1) Performance capabilities during stabilized autorotative descent are useful pilot tools to assist in the management of a Category B rotorcraft when all engines fail. This information is also useful in determining the suitability of available landing areas along a given route segment.

(2) Two speeds are of particular importance, the speed for minimum rate of descent and the speed for best angle of glide. These speeds along with glide distance information are required as flight manual entries per FAR § 29.1587. The recommended speed for autorotation is usually optimized to assure an effective flare capability and yet be slow enough to allow a controlled, relatively slow touchdown condition. Recommended autorotation speed is ordinarily between the minimum rate of descent and maximum glide angle speeds.

An autorotative descent starting at least 1000 feet above the ground and at the speed published in the RFM, 100% RPM value will be demonstrated. Small turns will be conducted in the descent. The maneuver will be terminated with power at a safe altitude.

The aircraft should be easily controllable and the difference between the mount and camera/sensor/light payload and the clean configuration is the evaluation point.

**A.2.3.3. Findings**

Satisfactory \_\_\_\_\_ Altitude Band HP \_\_\_\_\_ Fuel Gage Reading \_\_\_\_\_

**A.2.4. FAR § 29.143 Controllability and Maneuverability**

**A.2.4.1. Applicable Regulation**

- ➔ (a) The rotorcraft must be safely controllable and maneuverable -
- ➔ (1) During steady flight; and
- ➔ (2) During any maneuver appropriate to the type, including -
- ➔ (i) Takeoff;
- ➔ (ii) Climb;
- ➔ (iii) Level flight;
- ➔ (iv) Turning flight;
- ➔ (v) Glide
- ➔ (vi) Landing (power on and power off);

➔(b) The margin of cyclic control must allow satisfactory roll and pitch control at VNE with

-

- (1) Critical weight;
- (2) Critical center of gravity;
- (3) Critical rotor rpm; and
- (4) Power off (except for helicopters demonstrating compliance with paragraph (f) of this section) and power on.

(c) A wind velocity of not less than 17 knots must be established in which the rotorcraft can be operated without loss of control on or near the ground in any maneuver appropriate to the type (such as crosswind takeoffs, sideward flight, and rearward flight), with -

- (1) Critical weight;
- (2) Critical center of gravity;
- (3) Critical rotor rpm; and
- (4) Altitude, from standard sea level conditions to the maximum altitude capability of the rotorcraft or 7,000 feet, whichever is less.

(d) The rotorcraft, after failure of one engine in the case of multiengine rotorcraft that meet Transport Category A engine isolation requirements, or complete engine failure in the case of other rotorcraft, must be controllable over the range of speeds and altitudes for which certification is requested when such power failure occurs with maximum continuous power and critical weight. No corrective action time delay for any condition following power failure may be less than -

- (1) For the cruise condition, one second, or normal pilot reaction time (whichever is greater); and
- (2) For any other condition, normal pilot reaction time.

(e) For helicopters for which a VNE (power off) is established under § 29.1505(c), compliance must be demonstrated with the following requirements with critical weight, critical center of gravity, and critical rotor rpm:

- (1) The helicopter must be safely slowed to VNE (power off), without exceptional pilot skill, after the last operating engine is made inoperative at power on VNE.
- (2) At a speed of 1.1 VNE (power off), the margin of cyclic control must allow satisfactory roll and pitch control with power off.

#### **A.2.4.2. Method of Compliance**

The general requirements for control and for maneuverability are summarized in section (a) of the AC, which is largely self-explanatory.

Section (b) specifies flight at V<sub>NE</sub> with critical weight, center of gravity (CG), rotor RPM, and power. Adequate cyclic authority must remain at V<sub>NE</sub> for nose down pitching of the rotorcraft and for adequate roll control.

The helicopter will be flown between 1000 and 3000 feet above ground. The test altitude will be dependent on traffic and terrain and conditions close to sea level pressure are desirable. V<sub>NE</sub> will be the value stated in the RFM for the test density altitude.

Qualitative measurement techniques (pilot opinion) will be used. The tests will include:

- Takeoff
- Climbing flight
- Forward flight to  $V_{NE}$ , not more than the published RFM limit at MCP (maybe less than MCP)
- Left & right 30 degree bank turns at  $V_{NE}$  and at MCP (maybe less than MCP)
- Take-off & Landings (Power **on** only).

The aircraft should be easily controllable and adequate cyclic margins should exist throughout the flight test points. The difference between the mount and sensor / camera / light payload and the clean configuration is the evaluation point.

**A.2.4.3. Findings**

Satisfactory \_\_\_\_\_ Cruise Altitude HP \_\_\_\_\_ Fuel Gage Reading \_\_\_\_\_

**A.2.5. FAR § 29.171 Stability: General**

**A.2.5.1. Applicable Regulation**

➔ The rotorcraft must be able to be flown, without undue pilot fatigue or strain, in any normal maneuver for a period of time as long as that expected in normal operation. At least three landings and takeoffs must be made during this demonstration.

**A.2.5.2. Method of Compliance**

Compliance with the requirements of this section can often be obtained for the VFR condition without any specific or designated flight testing. Demonstrate that the aircraft can be satisfactorily flown throughout the maximum endurance capabilities of the rotorcraft including night and turbulence conditions if those are critical. This test should be conducted with minimum required systems in the aircraft and with minimum flight crew. Compliance for this requirement will be evaluated throughout the test program.

**A.2.5.3. Findings**

Satisfactory \_\_\_\_\_

**A.2.6. FAR § 29.251 Vibration**

**A.2.6.1. Applicable Regulation**

➔ Each part of the rotorcraft must be free from excessive vibration under each appropriate speed and power condition.

**A.2.6.2. Method of Compliance**

This flight requirement may be both a qualitative and quantitative flight evaluation. Section 29.571(a) contains the flight load survey requirement that results in accumulation of vibration quantitative data. Section 29.629 generally requires quantitative data to show freedom from flutter for each part of the rotorcraft including control or stabilizing surfaces and rotors.

The aircraft should have a good track & balance for this evaluation. The airspeed should be evaluated at 20 kt increments out to the RFM VNE speed. Variations in rotor RPM expected in normal flight should be evaluated. Changes in vibration are best sensed in the cyclic and pedal controls. The stability of the camera/sensor image will be a good indicator.

The pilot will make a subjective evaluation of the difference between the mount and sensor / camera/ light payload and the clean configuration is the evaluation point. Compliance with this requirement will be evaluated during testing of FAR §29.143 Controllability and Maneuverability.

**A.2.6.3. Findings**

Satisfactory \_\_\_\_\_

**A.2.7. FAR § 29.773 Pilot Compartment View**

**A.2.7.1. Applicable Regulation**

- (a) Nonprecipitation conditions. For nonprecipitation conditions, the following apply:
  - ➔ (1) Each pilot compartment must be arranged to give the pilots a sufficiently extensive, clear, and undistorted view for safe operation.
  - ➔ (2) Each pilot compartment must be free of glare and reflection that could interfere with the pilot's view. If certification for night operation is requested, this must be shown by night flight tests.
- (b) Precipitation conditions. For precipitation conditions, the following apply:
  - (1) Each pilot must have a sufficiently extensive view for safe operation—
    - (i) In heavy rain at forward speeds up to VH; and
    - (ii) In the most severe icing condition for which certification is requested.
  - (2) The pilots must have a window that—
    - (i) Is openable under the conditions prescribed in subparagraph (1) of this paragraph; and
    - (ii) Provides the view prescribed in that subparagraph.

**A.2.7.2. Method of Compliance**

The section outlines requirements for pilot view in fairly general terms. The aircraft was approved with the installed glareshield and instrument panel that meet the rules. Any additional equipment/monitors must be positioned so as not to limit or obstruct the pilot's field of view. There will be some cases where the installation will be temporary and for a unique mission and consideration should be given for these limited cases and time.

If night operations are expected with an operational system, a "dark cockpit" or night evaluation will be necessary to insure the glare/reflection will not interfere with the pilot duties. A limitation to the use at night is an option.

**A.2.7.3. Findings**

Satisfactory \_\_\_\_\_

**A.2.8. FAR § 29.787 Cargo & Baggage Compartment**

**A.2.8.1. Applicable Regulation**

Cargo and baggage compartments.

(a) Each cargo and baggage compartment must be designed for its placarded maximum weight of contents and for the critical load distributions at the appropriate maximum load factors corresponding to the specified flight and ground load conditions, except the emergency landing conditions of Sec. 29.561.

(b) There must be means to prevent the contents of any compartment from becoming a hazard by shifting under the loads specified in paragraph (a) of this section.

➔ [(c) Under the emergency landing conditions of Sec. 29.561, cargo and baggage compartments must--

(1) Be positioned so that if the contents break loose they are unlikely to cause injury to the occupants or restrict any of the escape facilities provided for use after an emergency landing; or

(2) Have sufficient strength to withstand the conditions specified in Sec. 29.561 including the means of restraint, and their attachments, required for the maximum authorized weight of cargo and baggage at the critical loading distribution.]

(d) If cargo compartment lamps are installed, each lamp must be installed so as to prevent contact between lamp bulb and cargo.

**A.2.8.2. Method of Compliance**

Amendment 29-31 adds two subparagraphs to § 29.787(c) which clarifies that cargo and baggage compartments should be designed to protect occupants from injury by the compartment contents during emergency landings. This may be done by location or by retention provisions.

The sensor/camera/light controllers and power supply must be located and secured in a position that will not endanger occupants in an emergency landing impact.

Consideration should be given to stowage and egress when filming in hovering flight. In some cases, this might not be possible.

**A.2.8.3. Findings**

Comment: \_\_\_\_\_

Satisfactory \_\_\_\_\_

**A.2.9. FAR § 29.1301 Function and Installation.**

**A.2.9.1. Applicable Regulation**

Each item of installed equipment must--

- ➔ (a) Be of a kind and design appropriate to its intended function
- (b) Be labeled as to its identification, function, or operating limitations, or any applicable combination of these factors;
- (c) Be installed according to limitations specified for that equipment; and
- ➔ (d) Function properly when installed.

**A.2.9.2. Method of Compliance**

For optional equipment, the emphasis on functioning is rather limited compared to that for required equipment. The conditions under which the optional equipment is evaluated should be recorded in the report. The major emphasis for this type of equipment should be to ensure it does not interfere with the operation of systems that are required for safe operation of the rotorcraft, and that the failure modes are acceptable and do not create any hazards.

During flight operations, operate all avionics and electrical systems. Complete the matrix below. The matrix is laid out with the newly installed equipment listed at the top of the page and all aircraft systems listed down the left side of the page. Note any EMI or RFI either TO or FROM the installed equipment. Note any anomalies or EMI/RFI interference to other instruments or indications during all testing phases of flight.

Each item must be checked. Check off each block if no interference is noted. If interference is present during the test, DO NOT CHECK THE BOX and explain in Comments section at end of section. If applicable, note relevant conditions (i.e. frequencies, OBI selection, function modes) under which the interference occurred.

**A.2.9.3. Findings**

<b>Interference?</b>	<b>5.0</b> 	<b>Camera/Sensor/Light</b>	<b>Position Controller</b>
Camera/Sensor/Light			
Position Controller			
VHF Comm 1			
VHF Comm 2			
VHF Comm 3			
VHF NAV 1			
VHF NAV 2			
ADF 1			
XPONDER 1			
Other Radios			
Audio 1			
Audio 2			
Standby Compass			
Engine Inst			
Fuel Gage			
Clock			
Voltmeter			
Ammeter			
Other			

<b>EMI / RFI Comments:</b>

Satisfactory \_\_\_\_\_



**Signatures**

General test findings \_\_\_\_\_

Pilot Signature \_\_\_\_\_

Mechanic/ Engineer \_\_\_\_\_

Other Flt Personnel Signature & Function \_\_\_\_\_