

Parts List			
ITEM	QTY	PART NUMBER	DESCRIPTION
1	4	MS20004-6	INTERNAL WRENCH CAP SCREW
2	(1) REF	DT-1 (SHOWN - NOT INCLUDED)	DOVE TAIL ASSY
3	8	MS20004-6	INTERNAL WRENCH CAP SCREW
4	1	AFM-DTFLR-1	ADPATER DT TO 5.5 STD PTRN
5	(1) REF	SENSOR AS REQUIRED	FLIR STAR SAFIRE III OR EQVL SENSOR (SHOWN - NOT INCLUDED)

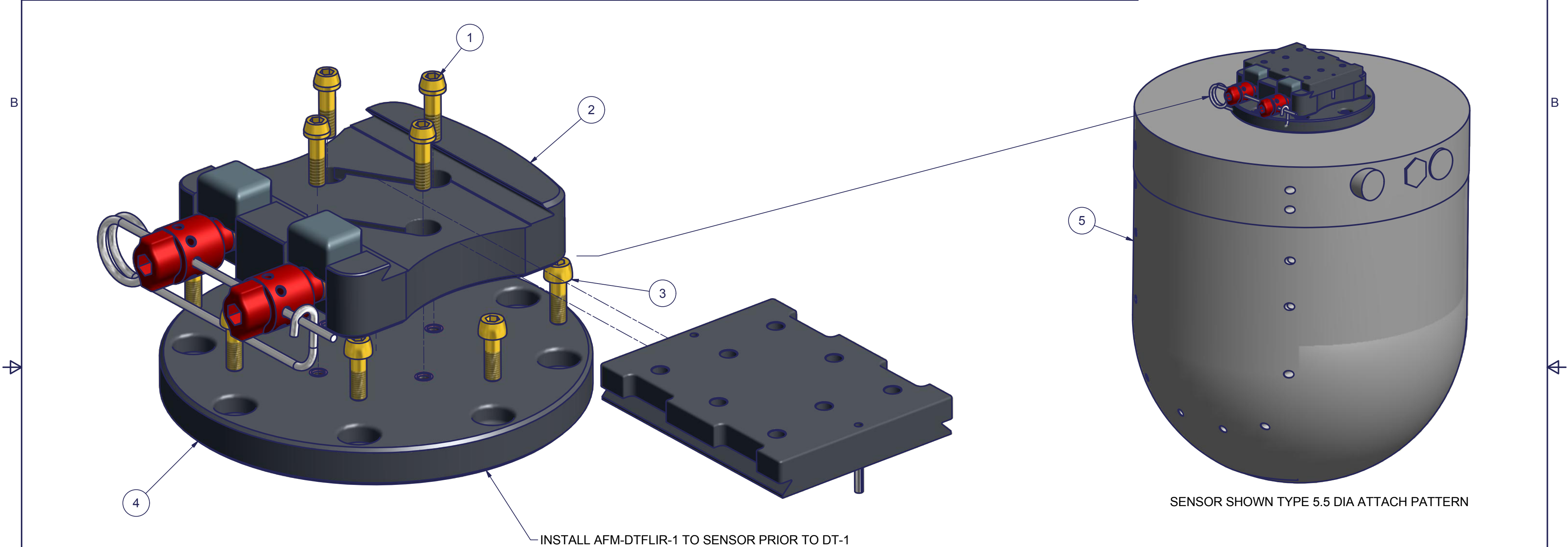

# AFM-DTFLR-1 ASSY

## GENERAL NOTES:

1. INSTALL AND TORQUE ALL HARDWARE PER AC 43.13-1B SECTION 3,4,5 UNLESS OTHERWISE NOTED
2. GRIP LENGTH IS TO BE DETERMINED AT INSTALLATION. NO THREADS ARE TO BE IN BEARING AND A MINIMUM OF TWO THREADS OR A MAXIMUM OF FOUR THREADS MUST BE SHOWING AFTER REACHING PROPER TORQUE ON FASTENERS. GRIP LENGTH GIVEN EITHER IN LIST OF MATERIALS OR CALLED OUT ON DRAWINGS ARE FOR REFERENCE ONLY
3. REFER TO SENSOR INSTALLATION LIMITATIONS AND REQUIREMENTS FOR HARDWARE TYPE, LENGHT AND TORQUE.
4. REFER TO DT-1 INSTALLATION INSTRUCTIONS FOR DT-1 ATTACHMENT AND LIMITATIONS

REVISION HISTORY		
REV	DESCRIPTION	DATE
N/C	ORIGINAL ISSUE	11/10/2010

UNLESS OTHERWISE NOTED ALL DIMENSIONS ARE INCH TOLERANCES  DECIMALS .X +/- 0.1 .XX +/- 0.03 .XXX +/- 0.005  ANGULAR +/- 0.5 DEG  BREAK ALL SHARP EDGES	<b>DRAWING</b>		<b>Airfilm Camera Systems, LLC</b> Georgetown, Ca		
	DRAWN S.P. Herring	11/10/2010			
	CHECKED		TITLE <b>DT TO 5.5 DIA ADAPTER ASSY, INSTALLATION</b>		
	APPROVED		SIZE <b>B</b>	DWG NO <b>AFM-DTFLR-1 INSTALL</b>	REV N/C
	PROPRIETARY NOTICE <small>THIS DRAWING AND SPECIFICATION IS THE PROPERTY OF AIRFILM CAMERA SYSTEMS, LLC AND SHALL NOT BE COPIED OR DIVULGED IN WHOLE OR IN PART AS THE BASIS FOR MANUFACTURING OR SALE OF THE ITEM OR ITEMS DISCLOSED.</small>		SCALE N/A	DO NOT SCALE DWG	SHEET 1 OF 1