

Parts List								
ITEM	AFM-PT275-1	AFM-PT350-1	PART NUMBER	DESCRIPTION	MATERIAL	MATERIAL SPEC	FINISH	FINISH SPEC
1	1	---	AFM-PT275-10	POLYETCH BRACKET ADPATER 275	ALUM 6061 PLATE	QQ-A-250/11	BLACK ANODIZE	MIL-A-8625 TYP II CL 2 MIL-A-8625 TYPII CL 2
2	---	1	AFM-PT350-10	POLYTECH BRACKET ADPATER 350	ALUM 6061 PLATE	QQ-A-250/11	BLACK ANODIZE	MIL-A-8625 TYP II CL 2 MIL-A-8625 TYPII CL 2
3	(REF A/R)	(REF A/R)	(DT-1) REF	DOVE TAIL ASSY				
4	4	4	MS20004-8	MACHINE SCREW				
5	4	4	AN960-416L	THIN WASHER				
6	4	4	MS21042-4	STOP NUT				
7	(A/R)	(A/R)	(REF ONLY)	REF ATTACHMENT HARDWARE SEE SENSOR REQUIREMENTS				
8	(A/R)	(A/R)	(REF PT SENSOR)	SENSOR REF ONLY				

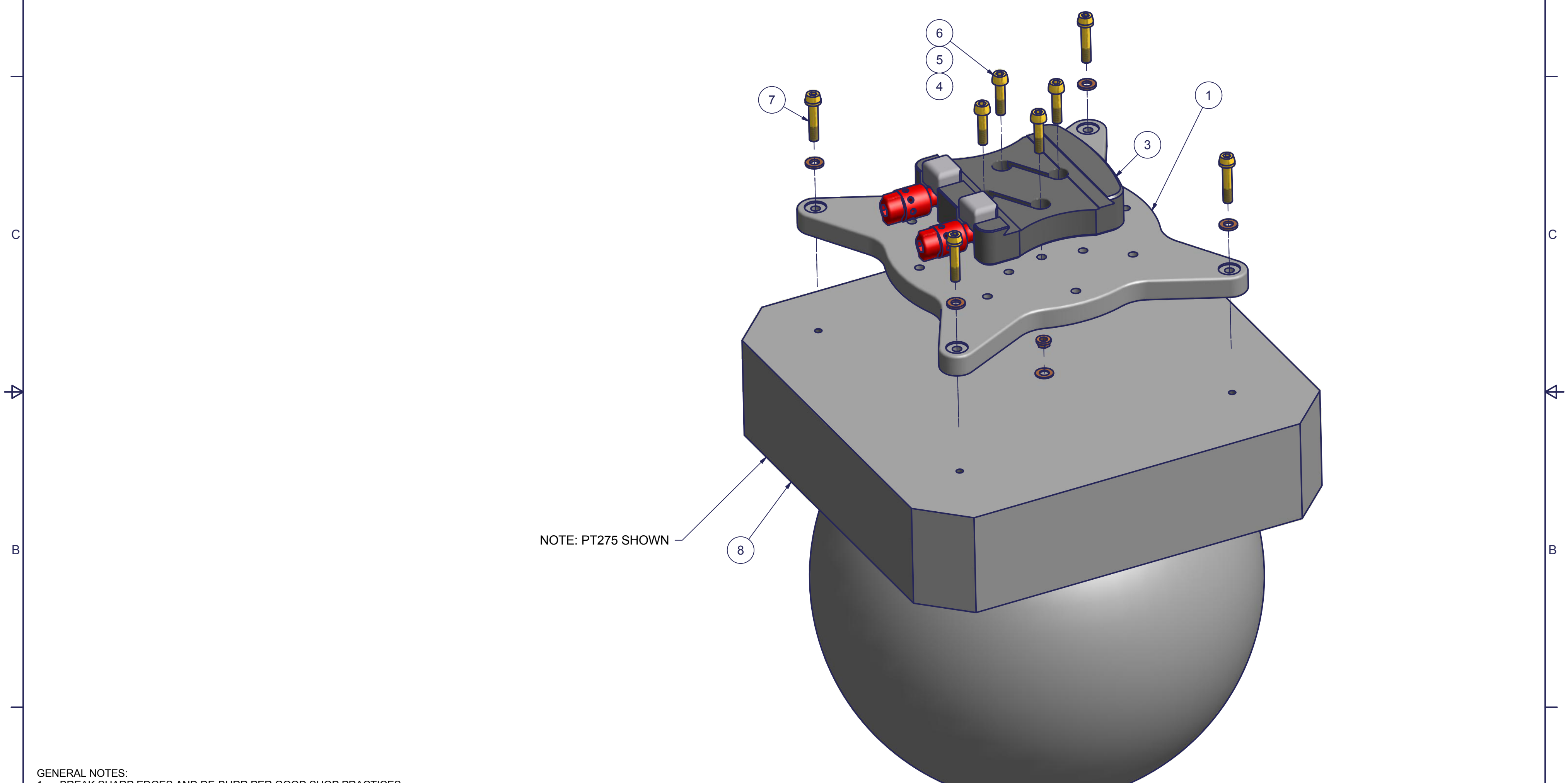

NOTE: PT275 SHOWN

- GENERAL NOTES:
- BREAK SHARP EDGES AND DE-BURR PER GOOD SHOP PRACTICES.
 - INSTALL AND TORQUE ALL HARDWARE PER AC 43.13-1B SECTION 3.4,5
 - GRIP LENGTH IS TO BE DETERMINED AT INSTALLATION. NO THREADS ARE TO BE IN BEARING AND A MINIMUM OF TWO THREADS OR A MAXIMUM OF FOUR THREADS MUST BE SHOWING AFTER REACHING PROPER TORQUE ON FASTENERS. GRIP LENGTH GIVEN EITHER IN LIST OF MATERIALS OR CALLED OUT ON DRAWINGS ARE FOR REFERENCE ONLY
 - UNLESS OTHERWISE NOTED ALL PARTS SHALL BE PROCESS FINISHED BEFORE ASSEMBLY
 - UNLESS OTHERWISE NOTED IDENTIFY ALL PARTS BY ENGRAVING TEXT .005 TO .010 BELOW PART SURFACE USING 0.065 BALL END MILL, OR LABEL WITH PERMANENT INK AND STAMP, OR LABEL WITH PERMANENT ADHESIVE PART LABEL, OR LASER ENGRAVING AFTER PROCESS COATINGS.

REVISION HISTORY		
REV	DESCRIPTION	DATE
N/C	ORIGINAL ISSUE	1/1/2012

UNLESS OTHERWISE NOTED ALL DIMENSIONS ARE INCH TOLERANCES DECIMALS .X +/- 0.1 .XX +/- 0.03 .XXX +/- 0.005 ANGULAR +/- 0.5 DEG BREAK ALL SHARP EDGES	DRAWING		Airfilm Camera Systems, LLC Georgetown, Ca		
	DRAWN <i>S.P. Herring</i>	1/1/2012			
	CHECKED <i>L. Ricca</i>	1/1/2012	TITLE	ADAPTER ASSY, AFM STANDARD TO POLY	
	APPROVED <i>B. Poe</i>	1/1/2012	SIZE	DWG NO	REV
PROPRIETARY NOTICE <small>THIS DRAWING AND SPECIFICATION IS THE PROPERTY OF AIRFILM CAMERA SYSTEMS, LLC AND SHALL NOT BE COPIED OR DIVULGED IN WHOLE OR IN PART AS THE BASIS FOR MANUFACTURING OR SALE OF THE ITEM OR ITEMS DISCLOSED.</small>			C	AFM-PT-1	N/C
SCALE N/A			DO NOT SCALE DWG	SHEET 1 OF 3	