

Parts List			
ITEM	QDD-1-1H	PART NO.	DESCRIPTION
1	1	QDD-1-10H	UPPER DOVETAIL BRACKET
2	1	QDD-1-20H	LOWER DOVETAIL BRACKET
3	1	QDD-1-30	LOCKING DOVETAIL
4	1	QDD-1-40	LOCKING BOLT
5	1	QDD-1-50	BUSHING
6	1	92070A250 -MMC	KEY LOCKING INSERT
7	1	92384A043 -MMC	QUICK PIN 1/4 X 3 INCH

B NOTE: ABOVE CHART REF ONLY - USE DWG QDD-1-1H FOR BOM

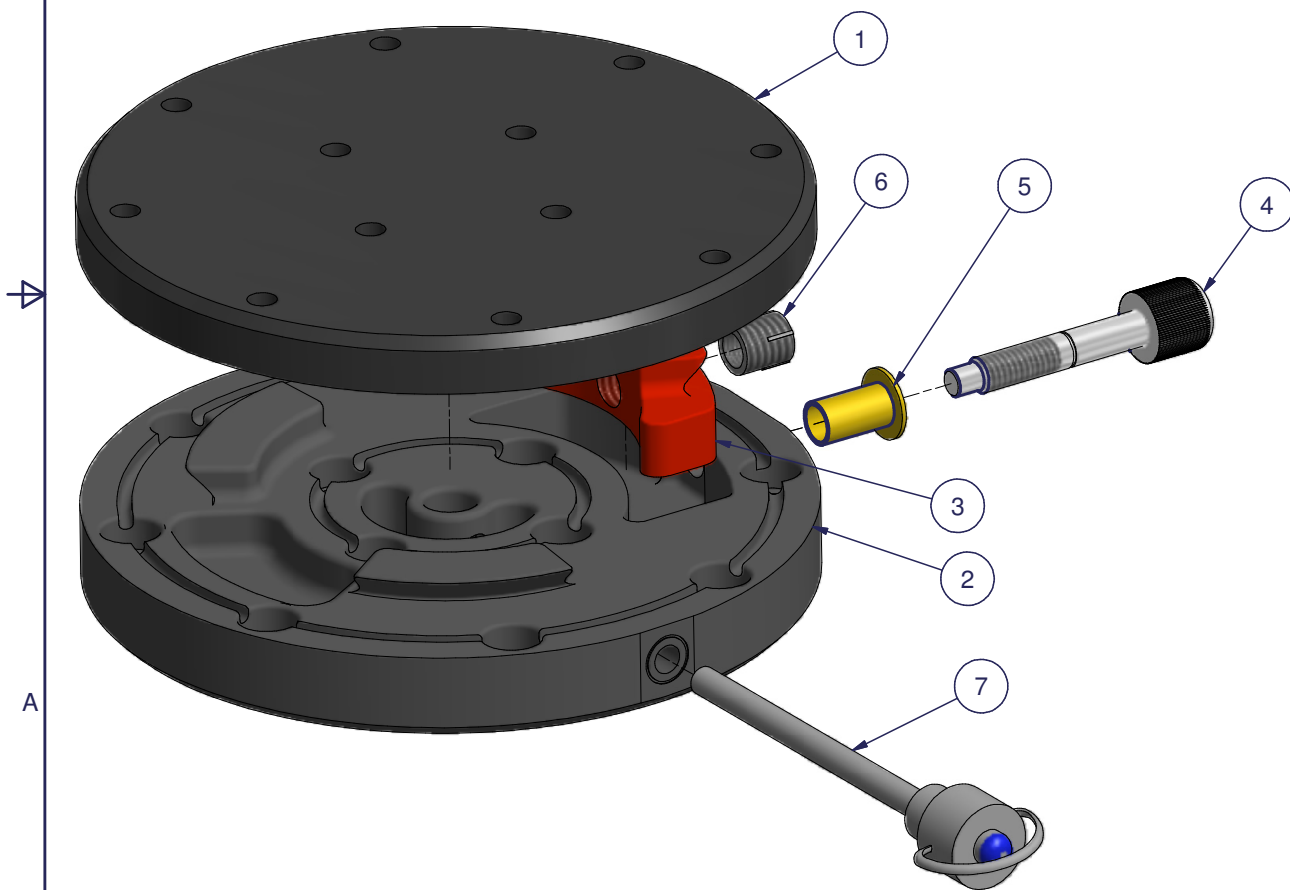

EXPLODED PARTS VIEW

ORDER INFORMATION:
P/N QDD-1-1H HEAVY DUTY UPPER & LOWER ASSY COMPLETE

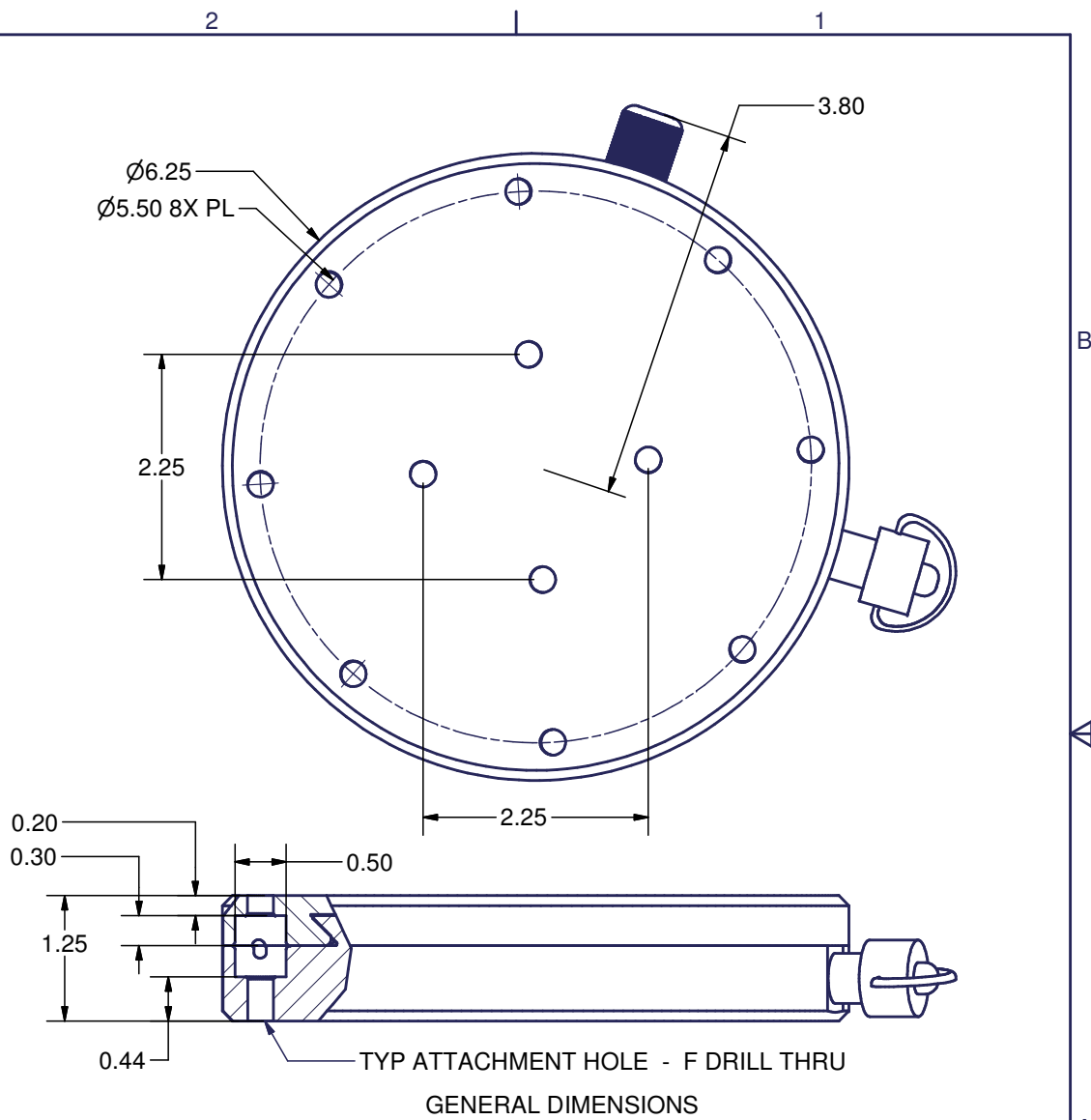

GENERAL DIMENSIONS

AirFilm Camera Systems	
Georgetown, Ca 530-333-0193 www.airfilm.com	
TITLE	
QUICK DISCONNECT DEVICE	
DWG NO	REV
QDD-1_1H	N/C
SHEET 1	OF 2

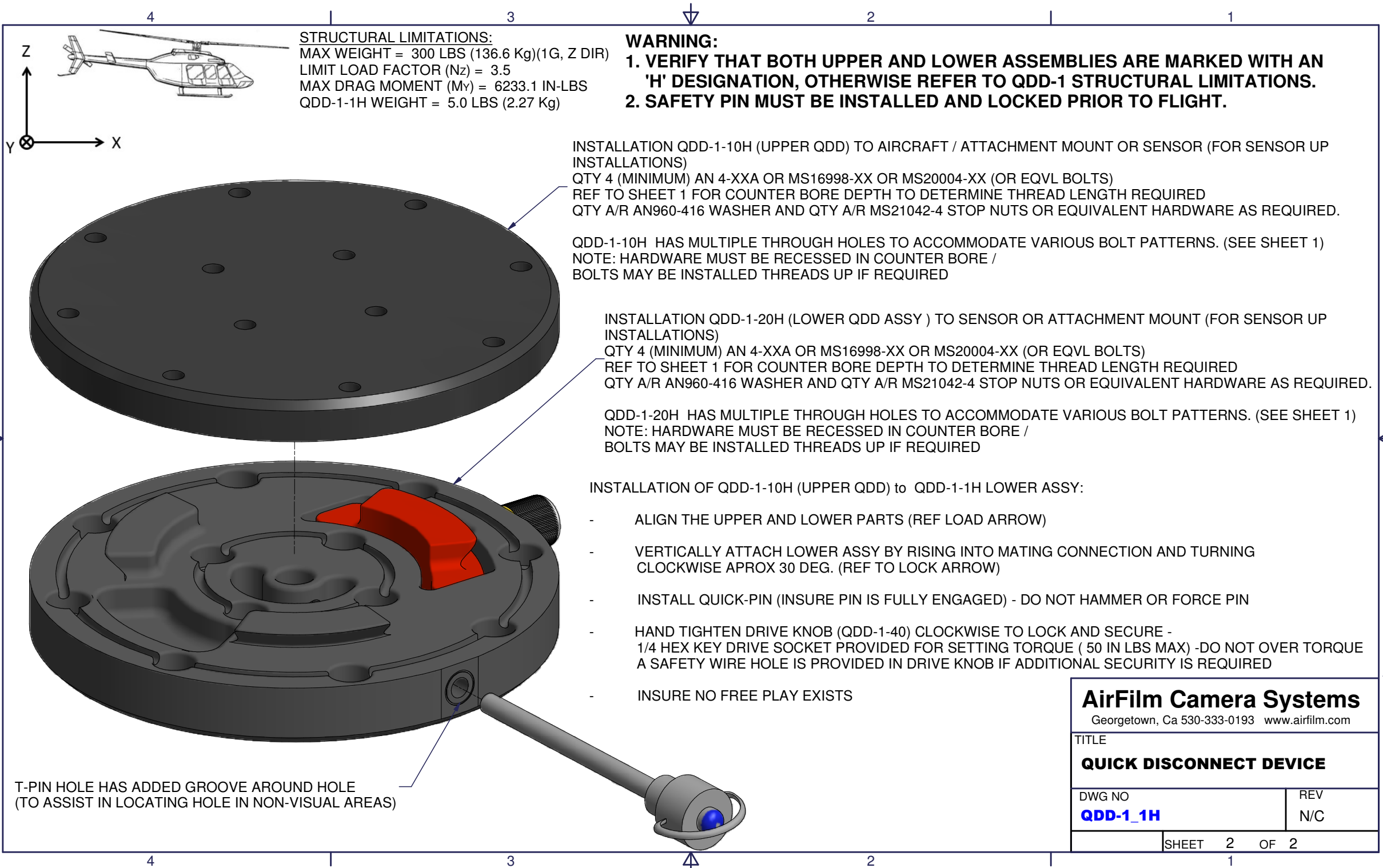

STRUCTURAL LIMITATIONS:
 MAX WEIGHT = 300 LBS (136.6 Kg)(1G, Z DIR)
 LIMIT LOAD FACTOR (Nz) = 3.5
 MAX DRAG MOMENT (My) = 6233.1 IN-LBS
 QDD-1-1H WEIGHT = 5.0 LBS (2.27 Kg)

WARNING:
 1. VERIFY THAT BOTH UPPER AND LOWER ASSEMBLIES ARE MARKED WITH AN 'H' DESIGNATION, OTHERWISE REFER TO QDD-1 STRUCTURAL LIMITATIONS.
 2. SAFETY PIN MUST BE INSTALLED AND LOCKED PRIOR TO FLIGHT.

INSTALLATION QDD-1-10H (UPPER QDD) TO AIRCRAFT / ATTACHMENT MOUNT OR SENSOR (FOR SENSOR UP INSTALLATIONS)
 QTY 4 (MINIMUM) AN 4-XXA OR MS16998-XX OR MS20004-XX (OR EQVL BOLTS)
 REF TO SHEET 1 FOR COUNTER BORE DEPTH TO DETERMINE THREAD LENGTH REQUIRED
 QTY A/R AN960-416 WASHER AND QTY A/R MS21042-4 STOP NUTS OR EQUIVALENT HARDWARE AS REQUIRED.

QDD-1-10H HAS MULTIPLE THROUGH HOLES TO ACCOMMODATE VARIOUS BOLT PATTERNS. (SEE SHEET 1)
 NOTE: HARDWARE MUST BE RECESSED IN COUNTER BORE / BOLTS MAY BE INSTALLED THREADS UP IF REQUIRED

INSTALLATION QDD-1-20H (LOWER QDD ASSY) TO SENSOR OR ATTACHMENT MOUNT (FOR SENSOR UP INSTALLATIONS)
 QTY 4 (MINIMUM) AN 4-XXA OR MS16998-XX OR MS20004-XX (OR EQVL BOLTS)
 REF TO SHEET 1 FOR COUNTER BORE DEPTH TO DETERMINE THREAD LENGTH REQUIRED
 QTY A/R AN960-416 WASHER AND QTY A/R MS21042-4 STOP NUTS OR EQUIVALENT HARDWARE AS REQUIRED.

QDD-1-20H HAS MULTIPLE THROUGH HOLES TO ACCOMMODATE VARIOUS BOLT PATTERNS. (SEE SHEET 1)
 NOTE: HARDWARE MUST BE RECESSED IN COUNTER BORE / BOLTS MAY BE INSTALLED THREADS UP IF REQUIRED

INSTALLATION OF QDD-1-10H (UPPER QDD) to QDD-1-1H LOWER ASSY:

- ALIGN THE UPPER AND LOWER PARTS (REF LOAD ARROW)
- VERTICALLY ATTACH LOWER ASSY BY RISING INTO MATING CONNECTION AND TURNING CLOCKWISE APROX 30 DEG. (REF TO LOCK ARROW)
- INSTALL QUICK-PIN (INSURE PIN IS FULLY ENGAGED) - DO NOT HAMMER OR FORCE PIN
- HAND TIGHTEN DRIVE KNOB (QDD-1-40) CLOCKWISE TO LOCK AND SECURE - 1/4 HEX KEY DRIVE SOCKET PROVIDED FOR SETTING TORQUE (50 IN LBS MAX) -DO NOT OVER TORQUE A SAFETY WIRE HOLE IS PROVIDED IN DRIVE KNOB IF ADDITIONAL SECURITY IS REQUIRED
- INSURE NO FREE PLAY EXISTS

T-PIN HOLE HAS ADDED GROOVE AROUND HOLE (TO ASSIST IN LOCATING HOLE IN NON-VISUAL AREAS)

AirFilm Camera Systems Georgetown, Ca 530-333-0193 www.airfilm.com	
TITLE QUICK DISCONNECT DEVICE	
DWG NO QDD-1_1H	REV N/C
SHEET 2 OF 2	