

Parts List							
ITEM	QTY	PART NUMBER	DESCRIPTION	MATERIAL	MATERIAL SPEC	FINISH	FINISH SPEC
1	(1)	(DT-1)	REF DOVE TAIL ASSY				
2	10	MS16998-45	CAP SCREW				
3	1	V380-10	TOP LID	6061 T651 (ALUM PLATE)	QQ-A-250/11	BLACK ANODIZE	MIL-A-8625 TY II CL 2 MIL-A-8625 TYP III CL 2
4	1	V380-11	FLOAT RING	6061 T651 (ALUM PLATE)	QQ-A-250/11	BLACK ANODIZE	MIL-A-8625 TY II CL 2 MIL-A-8625 TY PIII CL 2
5	44	MS24694-S51	MACHINE SCREW				
6	22	SM4-090-A	ISOLATOR WIRE ROPE (INSTALL QTY 11 THRU 22 AS REQUIRED)				
7	10	MS21209-F6-10 25X375	LOCKING HELICOIL				
8	1	V380-12	LOWER RING	6061 T651 (ALUM PLATE)	QQ-A-250/11	BLACK ANODIZE	MIL-A-8625 TY II CL 2 MIL-A-8625 TYP III CL 2
10	8	MS35338-44	LOCK WASHER				
11	4	MS21042-4	STOP NUT				
12	8	AN4-7A	HEX BOLT				
13	(1)	(380 FLIR SYSTEM)	REF FLIR CAMERA SYSTEM				
14	4	AN4-10A	HEX BOLT				
15	4	AN960-416L	WASHER THIN				

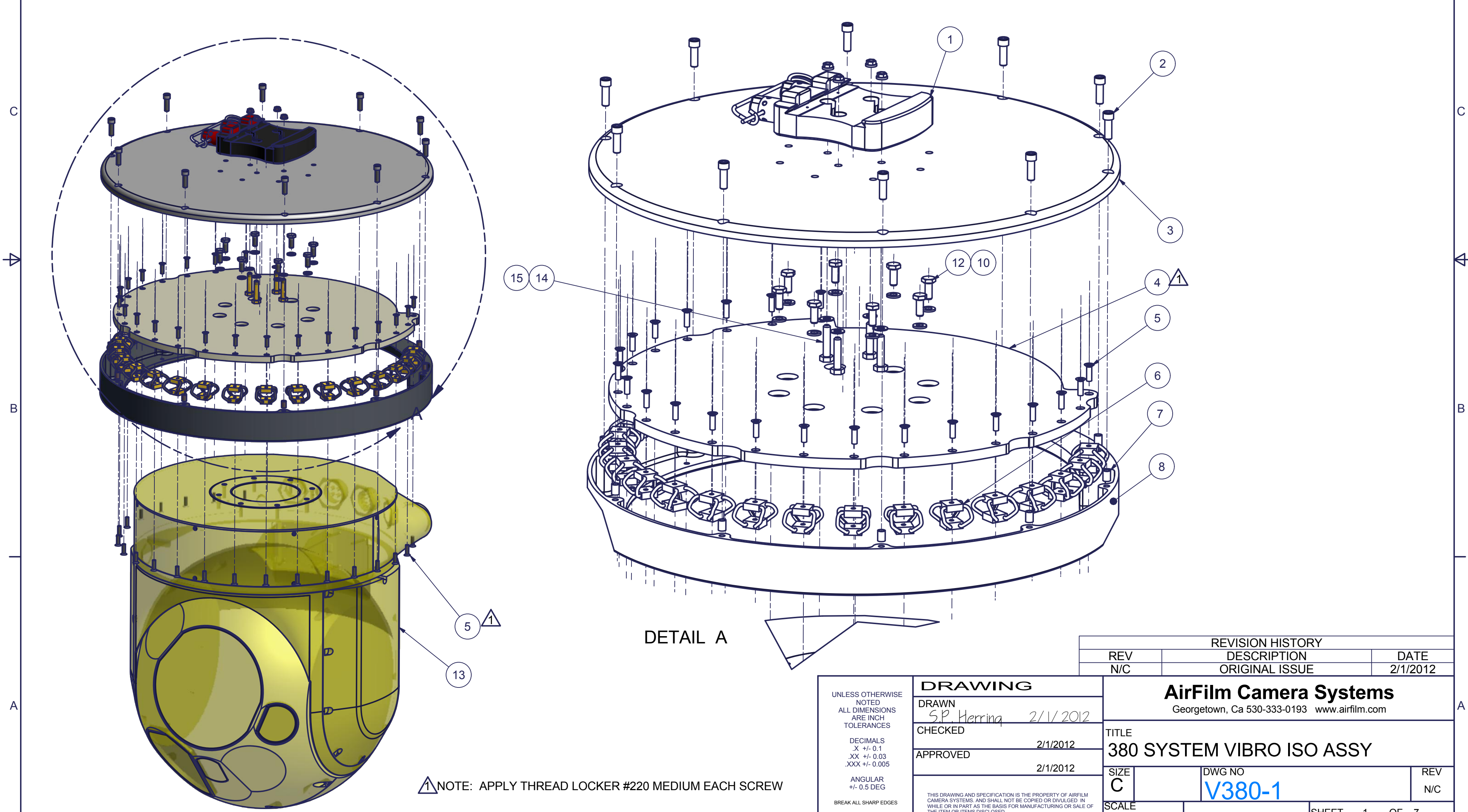

REVISION HISTORY		
REV	DESCRIPTION	DATE
N/C	ORIGINAL ISSUE	2/1/2012

DRAWING	
DRAWN	S.P. Herring 2/1/2012
CHECKED	
APPROVED	2/1/2012
	2/1/2012

AirFilm Camera Systems Georgetown, Ca 530-333-0193 www.airfilm.com		
TITLE 380 SYSTEM VIBRO ISO ASSY		
SIZE C	DWG NO V380-1	REV N/C
SCALE		SHEET 1 OF 7

NOTE: APPLY THREAD LOCKER #220 MEDIUM EACH SCREW

UNLESS OTHERWISE NOTED ALL DIMENSIONS ARE INCH TOLERANCES
 DECIMALS
 .X +/- 0.1
 .XX +/- 0.03
 .XXX +/- 0.005
 ANGULAR
 +/- 0.5 DEG
 BREAK ALL SHARP EDGES

THIS DRAWING AND SPECIFICATION IS THE PROPERTY OF AIRFILM CAMERA SYSTEMS, AND SHALL NOT BE COPIED OR DIVULGED IN WHOLE OR IN PART AS THE BASIS FOR MANUFACTURING OR SALE OF THE ITEM OR ITEMS DISCLOSED.

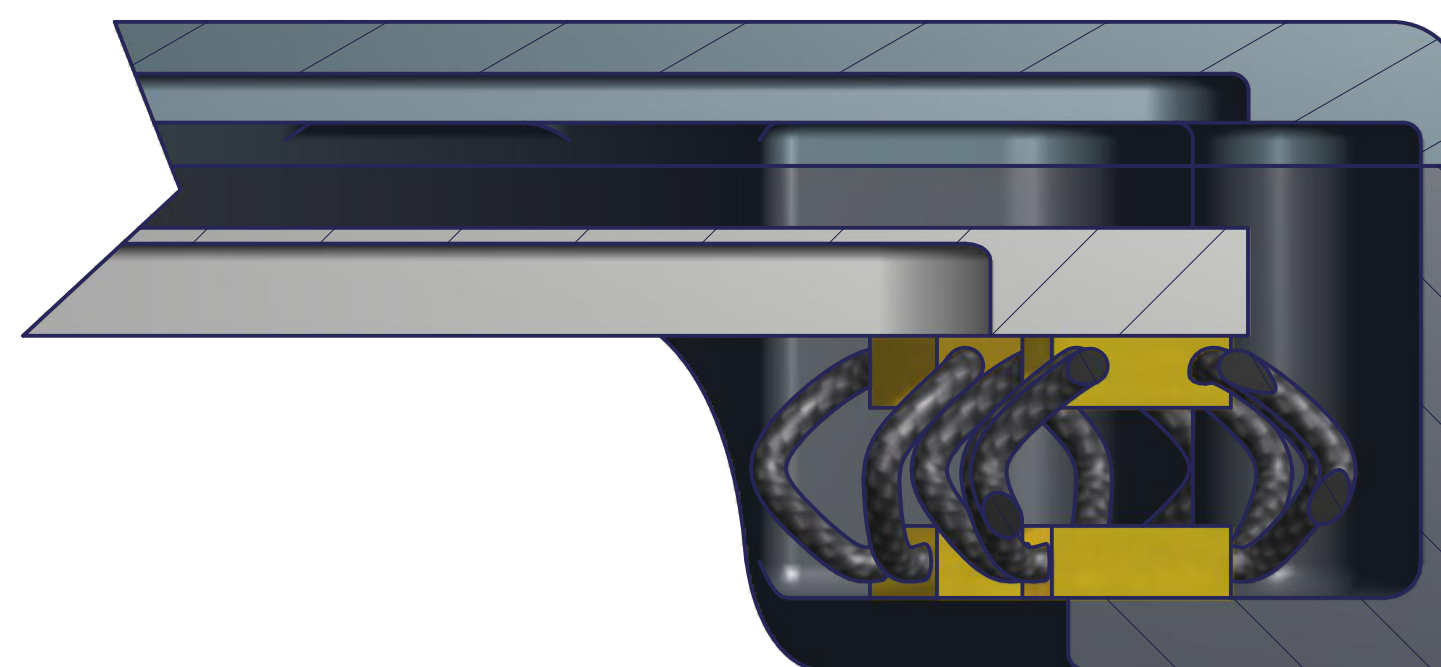
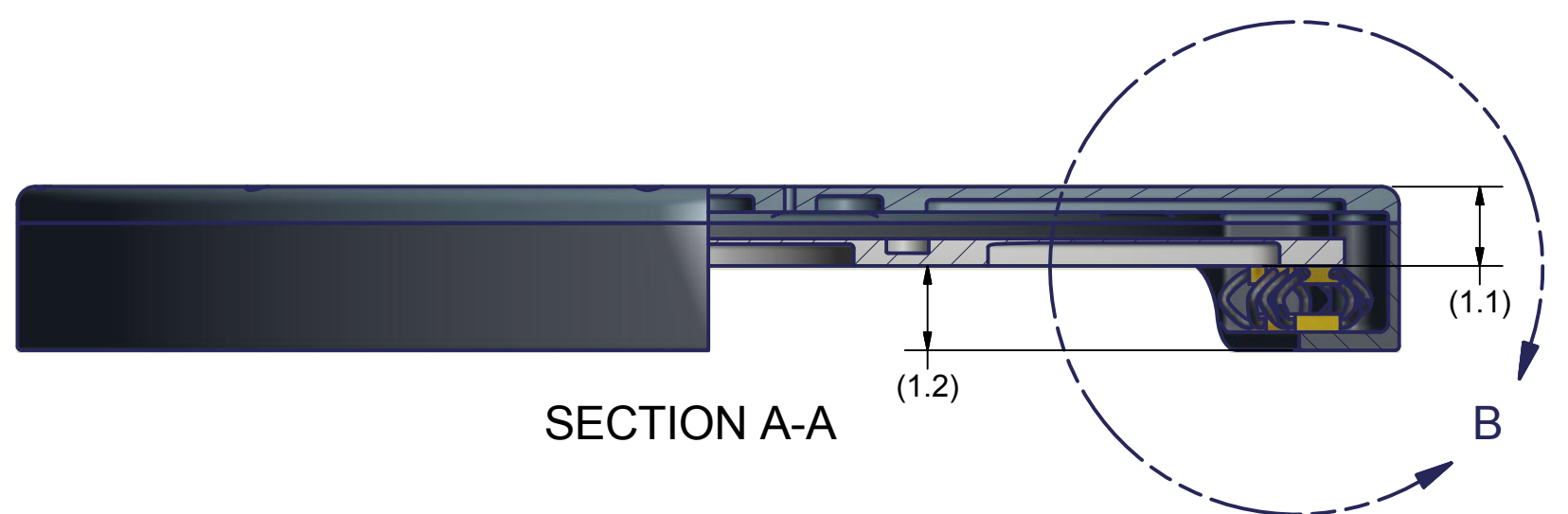
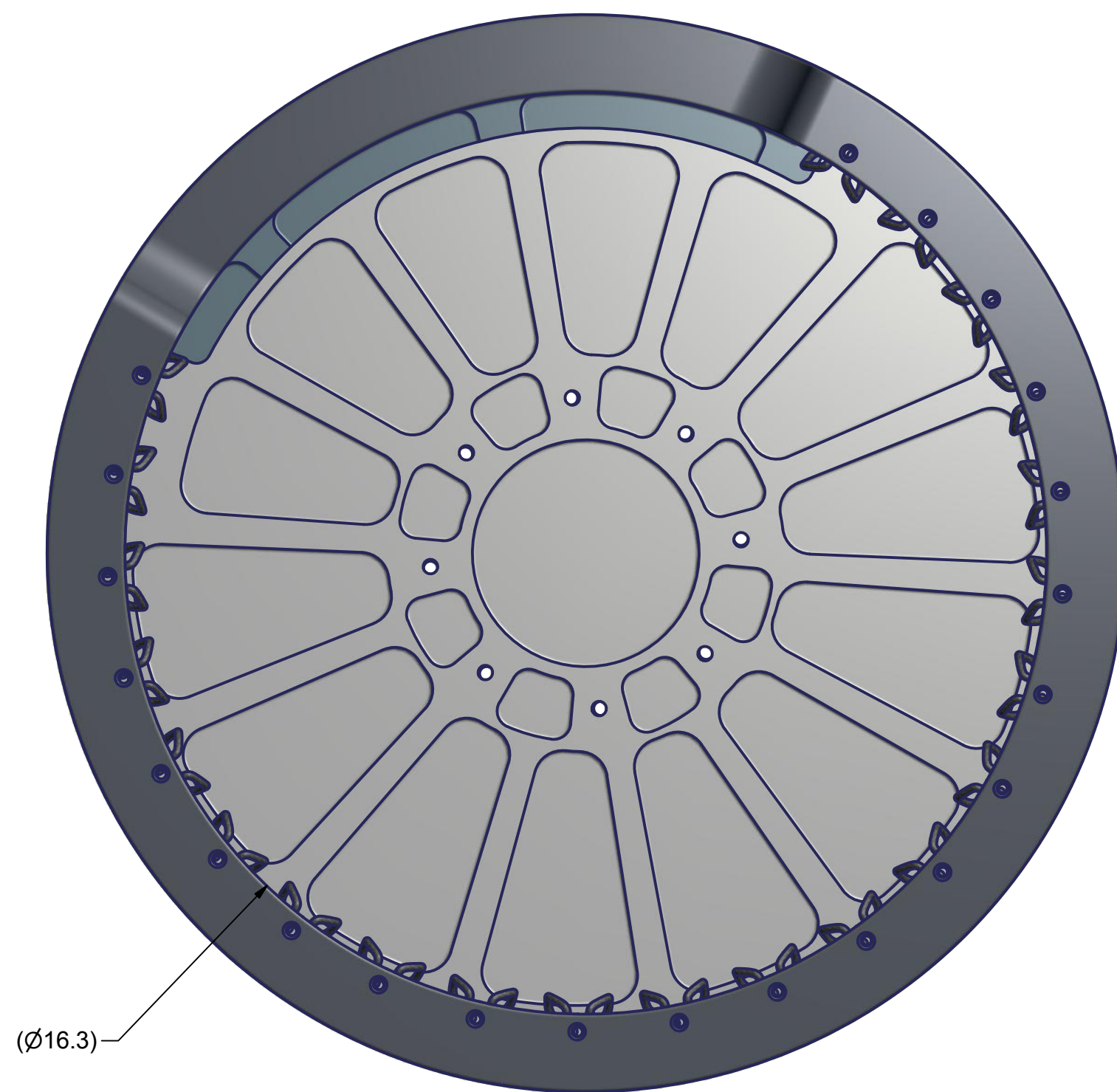
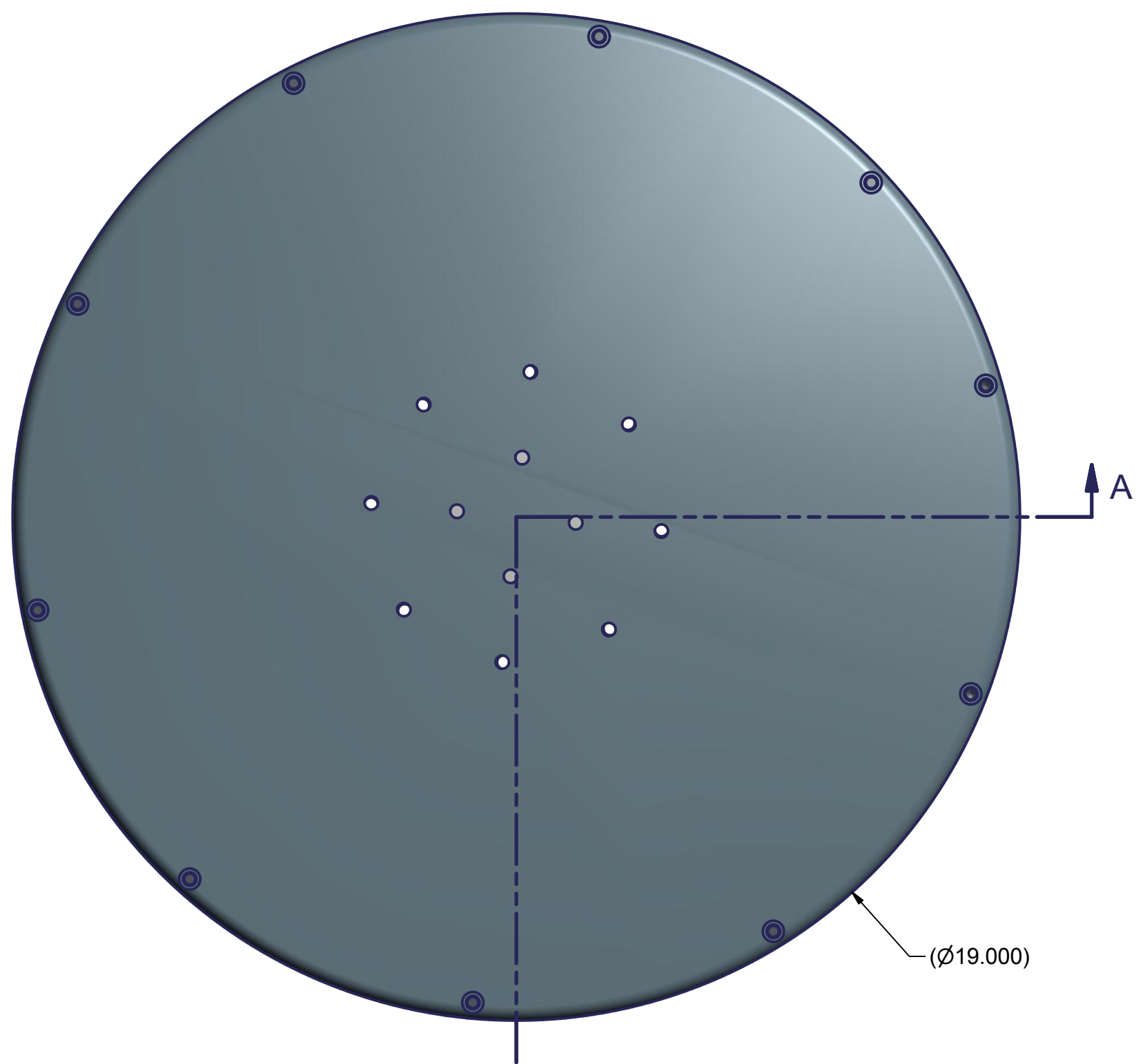

DETAIL B

SECTION A-A

GENERAL DIMENSIONS VIEWS

Airfilm Camera Systems, LLC <i>Georgetown, Ca</i>			
TITLE 380 SYSTEM VIBRO ISO ASSY			
SIZE C	DWG NO V380-1	REV N/C	
SCALE N/A	DO NOT SCALE DWG	SHEET 2	OF 7

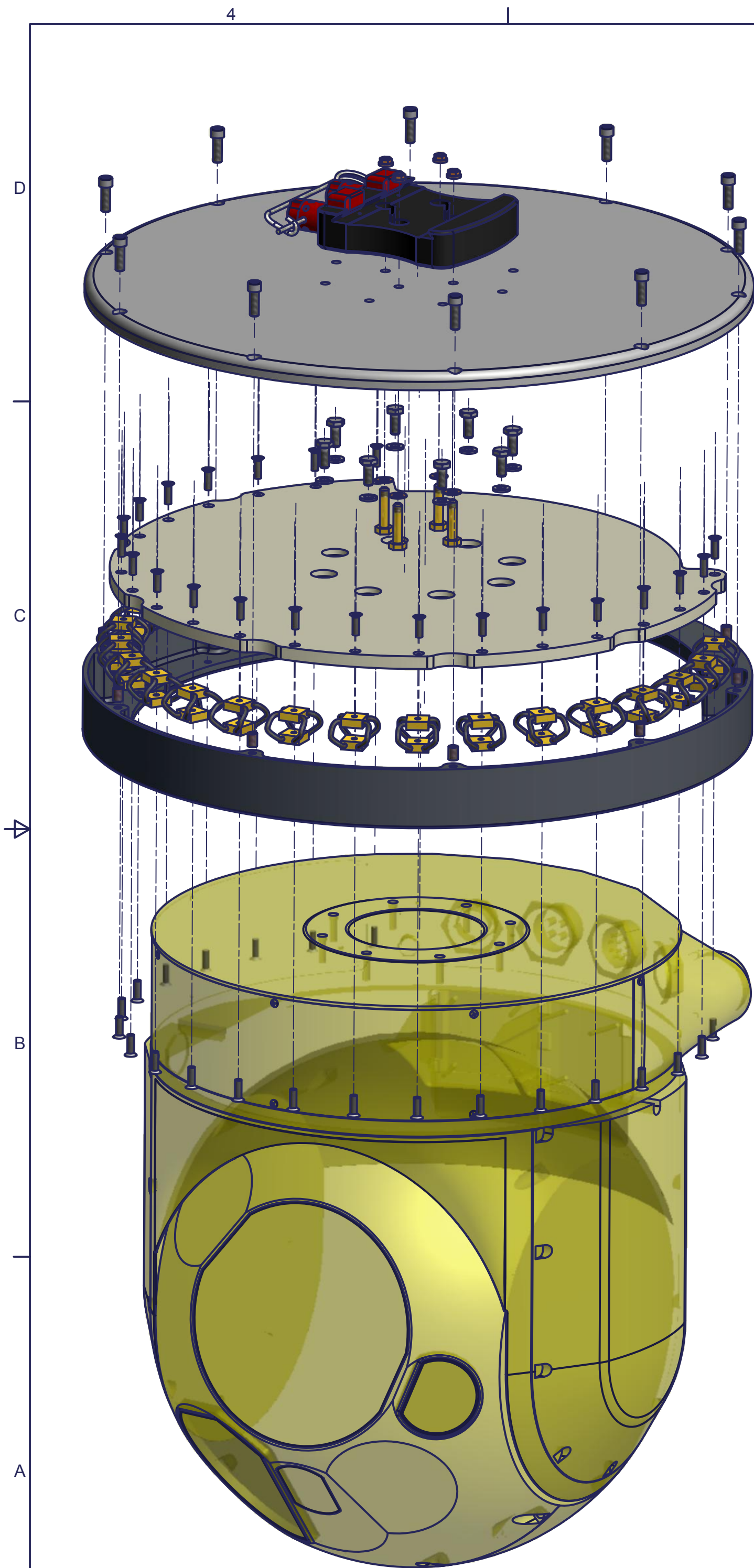

AUX EXPLODED VIEW

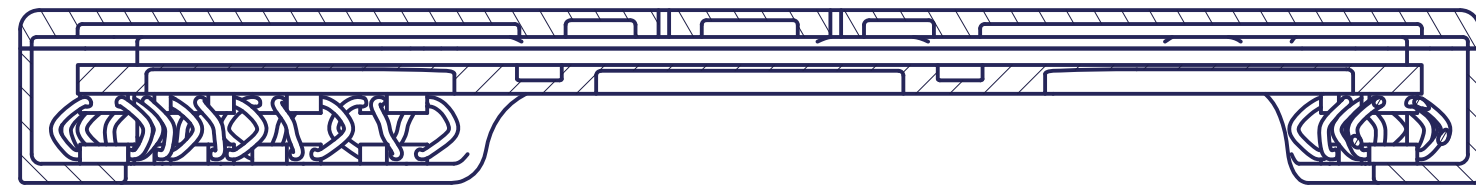
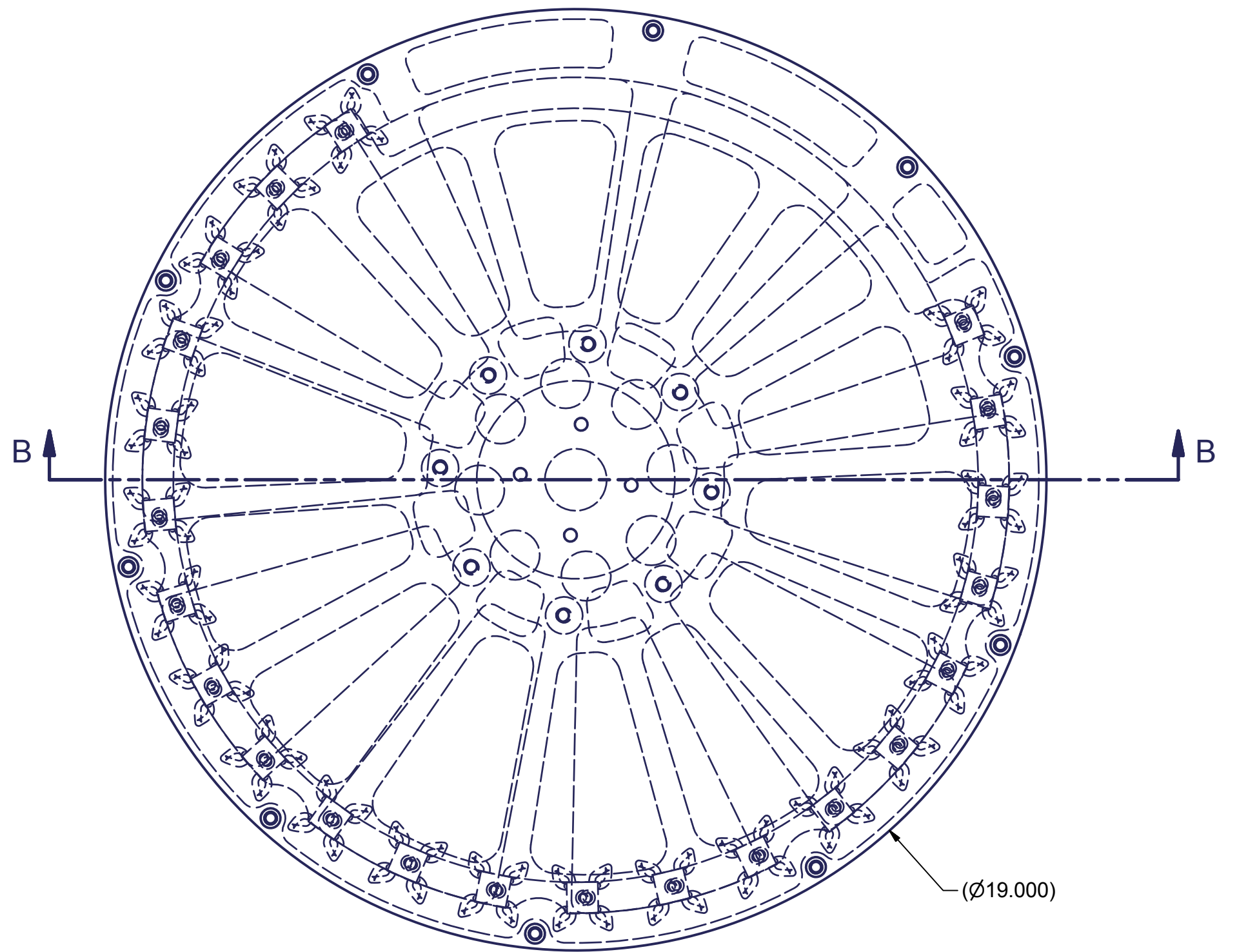

SECTION B-B
SCALE .4

Airfilm Camera Systems, LLC <i>Georgetown, Ca</i>			
TITLE 380 SYSTEM VIBRO ISO ASSY			
SIZE C	DWG NO	V380-1	
SCALE N/A	DO NOT SCALE DWG	SHEET 3	OF 7
		REV N/C	

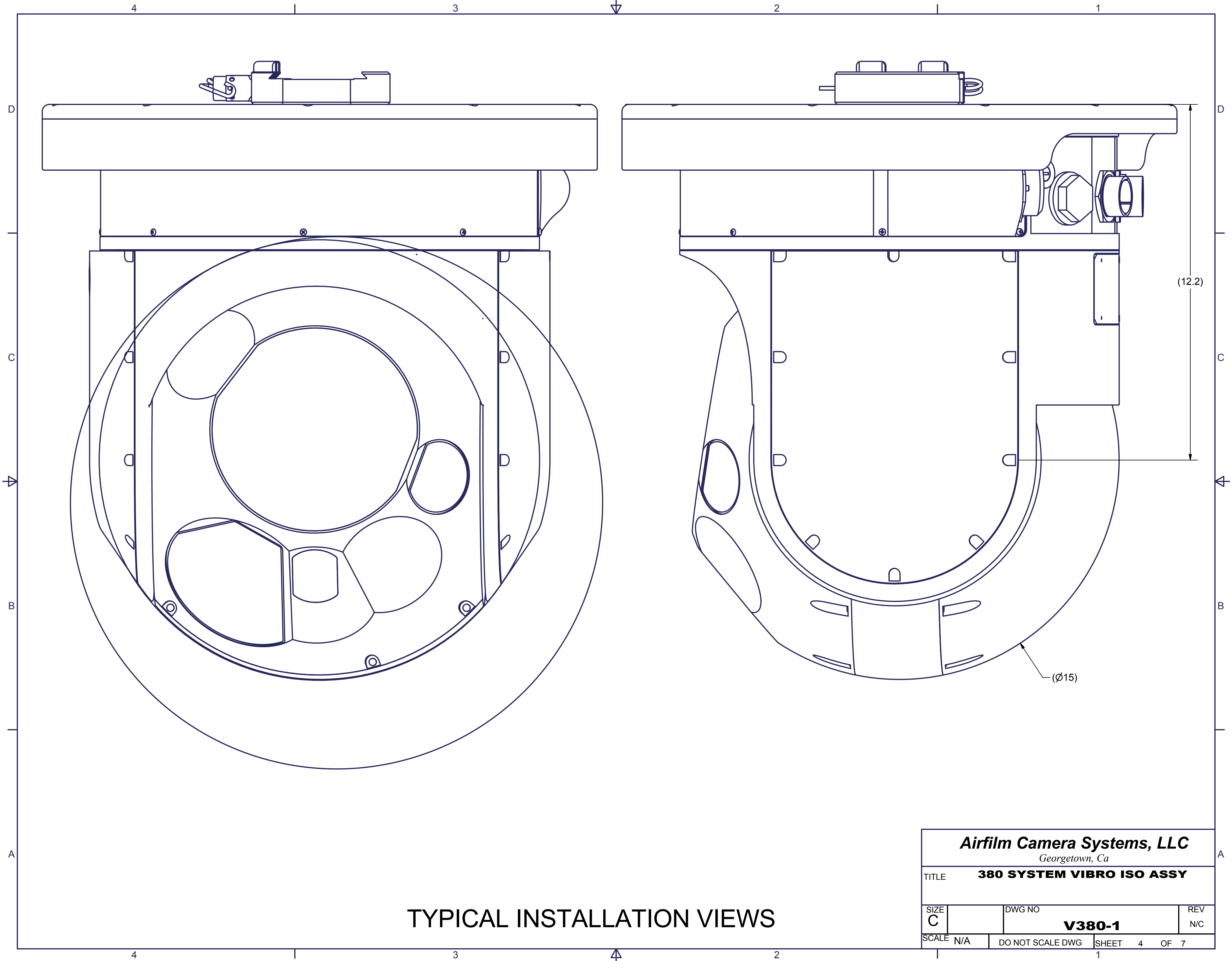

TYPICAL INSTALLATION VIEWS

Airfilm Camera Systems, LLC <i>Georgetown, Ca</i>			
TITLE		380 SYSTEM VIBRO ISO ASSY	
SIZE	DWG NO	REV	
C	V380-1	N/C	
SCALE	DO NOT SCALE DWG	SHEET	4 OF 7
N/A		1	